

**Volume-6**  
**Study of**  
**Hydraulic Seals,**  
**Fluid Conductor**  
**And Hydraulic Oil**

**Q.S. Khan**

B.E. (Mech.)

**TANVEER PUBLICATIONS**

Hydro-Electic Machinery Premises

12-A, Ram-Rahim Uduog Nagar, Bus Stop Lane, L.B.S.  
Marg, Sonapur, Bhandup (west), Mumbai - 400 078 (India)

E-mail: [hydelect@vsnl.com](mailto:hydelect@vsnl.com)

[www. Tanveerpublication.com](http://www.Tanveerpublication.com)

Tel : 022-25965930,25964075-8108000222

# CONTENTS

---

<b>5. Hydraulic Fluids</b>	<b>5-1 To 5-7</b>
5.1 Definitin of Hydraulic Fluids	
5.2 Types of Hydraulic Fluides	
5.3 Hydraulic Oil produced by Indian Refineries	
5.4 Cavitation	
5.5 De-aeration	
5.6 Maintenance of Hydraulic Fluides	
5.7 Commonly Selected Viscosity of Hydraulic Fluid	
5.8 Standardization of Viscosity	
5.9 ISO Viscosity Classification	
5.10 Specification of Hydraulic Oil	
<b>6. Fluid Conductors</b>	<b>6-1 To 6-7</b>
6.1 Importance of Fluid Conductor	
6.2 Criteria of Selection of Fluid Conductor	
6.3 Manifold Blocks	
6.4 Pipes and Tubes	
6.5 End-fitting of Pipes and Tubes	
6.6 Anti-Bow-off-Feature	
6.7 Material of End-fitting	
6.8 Hoses	
6.9 Factor Considered while selecting a Hose	
6.10 Classification of Hoses	
6.11 Types of Hose End-fittings	
6.12 Material of End-fittings	
6.13 Common causes of End-fitting leakage	
6.14 Installation and Fixing of Hose Pipe	
6.15 Common problems of Hoses	
6.16 Precaution against Accidents	
6.17 Design and comissioning of Fluid Conductor	
<b>7. Hydraulic Seals</b>	<b>7.1 to 7.33</b>
7.1 Mechanics of Sealing	
7.2 Factors affecting the performance of Seals	
7.3 Compatibility of Seal Material with Hydraulic Fluid	
7.4 Temperature	
7.5 Elastomer	
7.6 Plastomer	
7.7 U-Seal	
7.8 Design and Dimension of U-Seal	
7.9 U-Seal for Corrosive Medium	
7.10 Rotary Seal	
7.11 Chevron Packing	
7.12 O-Ring	
7.13 Types of O-Ring	

- 7.14 Back-up Rings
- 7.15 Guide-ring
- 7.16 Design Description about O-ring
- 7.17 Composite Seal
- 7.18 Compact Seal
- 7.19 Wiper Seal
- 7.20 Installation of Seal

## Chapter 5

**HYDRAULIC FLUIDS**

**5.1** Hydraulic fluid carries energy in form of pressure and converts it into force with linear or rotary motion. It has a job to do in a hydraulic system. Hence it must be selected in such a way that it matches with duty that it has to perform.

Performance of a hydraulic system depends upon performance of a hydraulic fluid. In following paragraph we will discuss some of the quality and characteristic, which a hydraulic fluid must possess to give best performance.

A good hydraulic fluid should possess following characteristics.

**5.1.1 Favorable Viscosity of oil :-**

A hydraulic fluid with too low viscosity will increase leakage and will not offer adequate lubrication between fine clearance of valve, pump and other moving hydraulic components. While a thick oil with high viscosity can cause inefficient operation due to high-pressure drops and viscosity drag. It also results in over heating of oil and cavitations in pump.

Hence viscosity of oil should suit to the requirement of system. Viscosity between 30 to 70 cSt is selected for general-purpose hydraulic machine.

Viscosity of oil changes with change in temperature, which is not desirable. Oil should have high viscosity index to exhibit less change in viscosity in wide temperature range. For general use oil should have minimum 90-95-viscosity index.

**5.1.2 Bulk Modulus/Compressibility of oil :-**

Bulk modulus is reciprocal of compressibility. Stiff fluid with low compressibility permits stable handling of heavy loads without sponginess. For efficient transmission of power, hydraulic fluid must have high Bulk Modulus.

**5.1.3 Low Foaming Tendency :-**

Air remains in hydraulic fluid in dissolved condition. When oil passes through orifice or throttle, there is a drop in pressure and cause release of air in form of Air-bubble. These Air-bubbles increase compressibility of fluid and results in spongy action, over-heating, cavitations etc. Hydraulic fluid should resist the formation of foam or Air-bubble. Additives are added to increase this property in oil.

**5.1.4 Resistance to Oxidation :-**

Mineral oil is composed of hydrocarbon, which tends to oxidize in presence of air, high temperature, water and metal particulate contamination in oil. Products of oxidation are acidic in nature and soluble as well as insoluble in oil. Soluble by-product tends to thicken the oil, while insoluble get deposited in form of sludge in filters, orifice and pipe line and closes them.

The oxidation rapidly degrades the oil. The extent of degradation is measured in neutralization number. Neutralization number is amount of potassium hydroxide (KOH) needed to neutralize one gram of oil sample. The more potassium hydroxide needed to neutralize one gram of oil indicate high amount of acidic by-product and corresponding high degradation of oil.

Neutralization number of 0.1 mg KOH/gm is recommended for good oil and it should not be more than 1 mg KOH/gm.

### **5.1.5 Good Heat Transfer Capability :-**

Hydraulic fluid involves in transmission of power. Loss of power in transition results in generation of heat. It is desirable that hydraulic fluid should readily absorb and give up heat and also should carry large amount of heat without excessive rise in temperature. Hydraulic fluid should have high thermal conductivity and high specific heat.

Hydraulic oil with 0.13 W/m °C thermal conductivity and specific heat of 1966J/Kgf°C at 40 °C are recommended.

### **5.1.6 Compatibility :-**

Hydraulic fluid is lifeline of hydraulic system. It comes in contact with all the metallic, non-metallic components of hydraulic system as well as human being operating and maintaining it. Hydraulic fluid should not react with any metal and non - metallic component. It should be non - corrosive and compatible, as well as non - toxic and non - allergic for the person using it.

### **1.1.7 Low-Volatility :-**

Hydraulic fluid should have low - volatility. This reduces evaporation and bubble formation, It also reduces fluid loss and dangerous cavitations.

### **5.1.8 Good Lubricity :-**

Hydraulic fluid should form oil film and reduce friction to minimize wear and tear of moving component and give long life to hydraulic system.

### **5.1.9 Fire-Resistance :-**

Hydraulic fluid should resist ignition and flame propagation for safe and accident free operation of hydraulic system.

No hydraulic fluid possesses all the favorable characteristics. Hence various types of fluids have been developed. Depending upon the requirements of hydraulic system they are selected and used.

## 5.2. TYPES OF HYDRAULIC FLUID

### 5.2.1 Petroleum Oils: -

Uses of paraffin base petroleum oil is more than all the other hydraulic fluid put together, because of their best lubricating property. When they are specifically refined and formulated with various additives to prevent rusting, oxidation, foaming, wear and other problem, they become most favorable hydraulic fluids. Their biggest drawback is their poor resistance for ignition and flame propagation. Hence when there is fire hazard fire - resistant fluids are used.

### 5.2.2 Phosphate-Ester :-

This is a synthetic hydraulic fluid. It is 5 to 7 times costlier than mineral oil. It has good lubricating and fire - resistance property. It also gives better performance at high temperature and pressure. It is less useful at lower temperature. It has high specific gravity hence pump should be carefully selected.

### 5.2.3 Water Glycols :-

These hydraulic fluids are true solutions and not emulsions. This fluid contain three components, mixture of water (35 to 40 %), a glycol and, a high molecular - weight water-soluble polyglycol. These fluids have good fire-resistance and lubricating property bellow 50 °C.

### 5.2.4 Water-In Oil Emulsions :-

These fluids are also called as “Invert Emulsions” and used for moderate duty fire-resistance applications. They consist of 35 to 40 % water dispersed in petroleum oil by means of an emulsifying additive.

They are superior in fire-resistance property as compared to mineral oil but inferior to phosphate esters and water-glycol fluids. Repeatedly freezing and melting cause two phase of oil and water to separate hence great care must be taken while using.

### 5.2.5 Oil/Synthetic Blends :-

This is a solution of petroleum oil and phosphate ester together with a stabilizing against. They are used where fire - hazard is moderate. Their fire-resistance characteristics reflect their composition and depend largely on the ratio of phosphate ester to petroleum oil.

### 5.2.6 Water Additive Fluids :-

There are two types of water - additive fluids. First is **oil-in-water emulsion**, it is soluble oils with water in continuous phase. It contains 2 to 10 % oil dispersed in water.

Second is **chemical-n-water fluid**, it contains 2 to 5 % chemical and 98 to 95 water.

These fluids have good fire - resistance property and cost only 5 to 10 % as compared to mineral oil. They have poor lubrication property hence pump and valves should be selected accordingly.

### 5.2.7 Chlorotri Fluoro Ethylene (CTFE) :-

One of the newly developed non - flammable hydraulic fluid is Chlorotri fluoro ethylene (CTFE). This fluid is developed by Wright Aeroautical Laboratories and used by Boeing Air-Craft, as

brake fluid, in the wheel-well hydraulics.

### 5.3. Hydraulic Oil Produced by Indian Refineries: -

In India, Bharat Petroleum Corporation Ltd., Hindustan Petroleum Corporation Ltd., and Indian Oil Corporation Ltd., manufactures hydraulic oil. International standard making authorities has specified certain standard viscosity for hydraulic oil. All the three Refineries produce hydraulic oil as per international standard. But they have given their own trade names to their products.

Trade name of hydraulic oil produced by Hindustan Petroleum begins with Enclo and then follows the value of viscosity. For example hydraulic oil with 32 cSt viscosity is know as Enclo32.

Trade name of hydraulic oil produced by Bharat Petroleum begins with Hydrol and then follows the value of viscosity. For example hydraulic oil with 32 cSt viscosity is know as Hydrol - 32, similarly Indian Oil called their product as Servo system - 32.

All the hydraulic oils of same viscosity produced by various manufacturers are almost same. Then also oils of same viscosity of various manufacturers or oils of various viscosity of same manufacturer should not be mixed together. As additives added by various manufacturers are different as well as in various grades additives are different and mutual reaction of various additives grouped together may produce harmful effect on oil as well as hydraulic system.

### 5.4. Cavitation: -

Hydraulic oil contains almost 8% of air in dissolved condition. In a hydraulic system oil is continuously pressurized in pump and it get de-pressurized after passing through various valves and orifices as it return back to tank. At high - pressure air remains dissolved in oil but as soon as pressure drops it get released in form of bubbles. These air-bubbles are called **air pockets** or **entrains**.

If the suction of pump is very near to oil exhaust (return line) or if the quantity of oil is less in tank, then again these air-bubbles get sucked in pump. Pump sucks oil, confines it in small chamber between vanes or gear or piston and cylinder in pump body. As shaft of pump rotates, and if hydraulic system connected to pump offer resistance to flow of oil, then as volume of oil chamber in pump get reduce, oil get compressed and pressurized. Air - bubble, which got sucked in pump along with oil also gets compressed and pressurized in pump body. As long as they remain in confined metallic chamber of pump body, they do not get chance to expand, but as soon as they come out from pump - body they explodes at pump outlet. This process is called **Cavitation**. This is extremely harmful to pump as they cause metal erosion, local excessive heating, hydraulic fluid deterioration, and ultimately destruction of pump.

Some experts believe that air - bubble instead of exploding they implode. But what ever the case may be, cavitation is extremely harmful to pump. It makes rattling sound similar to that of handful of stones tossed into the pump.

Air - bubble in hydraulic system also produces various undesirable effects such as spongy action, lack of precision in movement and sequence etc. Hence formation and suction of air - bubble always should be avoided.

To avoid formation of air - bubble, oil with correct viscosity and low volatility should be selected. Suction filter should be of correct mess size (generally 125-micron size is used) oil level should not be too low. Working temperature should not be too high, suction of pump should be away from exhaust line with a baffle in between.

### 5.5. De-aeration:-

Hydraulic oil does have anti-foaming additives. Which promotes air - bubble to rise to oil surface in oil tank and get released. But air - bubble should have sufficient time for doing so.

If the oil storage capacity of oil tank is 4 to 5 time the discharge capacity of pump in a minute. Then to get re - circulated complete oil will take 4 to 5 minute times. This much time is sufficient for large amount of air - bubble to get released from oil, provided exhaust and suction are on opposite of tank and baffles are provided to stop foam to get sucked. This process of releasing air - bubble from oil is known as **De - Aeration**.

### 5.6. Maintenance of Hydraulic Fluids: -

For good maintenance of hydraulic fluid following guide-lines should be followed.

1. Fluid filtration is very important to keep contamination level down. Every hydraulic system should have suction filter, return - line filter, filter at oil filling point, and filter in Air - breather (for Air). Generally suction filter of 125 micron, return - line filter of 25 micron and 200 mesh-screen on the oil filling point of reservoir are used.

2. Use correct viscosity of oil to avoid heating and degradation. Generally 30 cSt is selected for working pressure upto 100 Bar at 38 °C, and 50 cSt above 100 Bar. Viscosity of oil also depends upon pump and other valve used.

3. Do not mix various grades and makes of oil.

4. Store oil inside or under roof, clean top of container, pipe and transfer pump before filling oil in reservoir.

5. Drain oil at recommended interval from reservoir.

6. Clean filter and replace cartridge of filter element at regular interval.

7. Flush and refill the system as recommended and fill oil upto proper level, over filling is also harmful.

8. At the time of maintenance avoid dust particle entering in valve and pump under repairing. Wash them with clean diesel before assembly.

9. Never return leaked fluid back to the system.

10. Scrape dealers purchase old hydraulic oil from companies, refine them and again sell them as new oil in market at very low price. Numbers of customers of author have spoiled their equipment using such old oil. As even though these are hydraulic oil but in long run additives added to improve anti-wear and other property get burnt-out, and oil lose their properties. This cause heavy wear of valves and pumps and cause internal leakage in hydraulic system.

Hence not only use correct grade of hydraulic oil, but also purchase it from right manufacturers and responsible dealer. Always purchase sealed container and check sealing and date of manufacturing before use.

### 5.7. Commonly Selected Viscosity of Hydraulic Fluid:-

Fluid	Viscosity (cSt)
Plain Water	3-4
High – water – contents synthetics.	3-4
Water - glycol.	43
Phosphate ester.	46
Oil - synthetic Blend.	65
Water – in – oil - emulsion.	100
Petroleum oil.	46



## 5.8. Standardization of Viscosity: -

Pumps and valves are designed after assuming certain values of viscosity. For convenience of consumer as well as manufacturer certain values of viscosity are fixed by international standard making organization. So that all pump and hydraulic equipment manufacturer make their product suitable for standard viscosity, as well as end-user also could get same or equivalent viscosity of fluid in their local market easily.

Following viscosities are standardized by ISO.

ISO VG2, 3, 5, 7, 10, 15, 22, 32, 46, 68, 100, 150, 220, 320, 460, 680, 1000, 1500.

In common hydraulic application, we use oil with 32, 46, and 68 viscosity only.

Following table indicate the importance of high viscosity index. As viscosity index is low change in kinematics viscosity too high as temperature rises. following table also indicate the importance of low working temperature. At higher temperature kinematics viscosity decreases, and oil become thinner. Thinner the oil it is more difficult for pump to develop pressure, and also more difficult for hydraulic valve to avoid oil leakage, and hold oil at higher pressure.

Hence oil temperature should always be below 50 °C.

## 5.9. ISO Viscosity Classification with Corresponding Kinematic Viscosities at Various Temperatures for Different Viscosity Indices: -

Approximate Kinematic viscosity at various temperature for different values of viscosity index

ISO Viscosity Grade	Kinematic Viscosity Range cSt at 40 °C	Viscosity Index = 0			Viscosity Index = 50			Viscosity Index = 95		
		cSt at 20°C	cSt at 37.8 °C	cSt at 50 °C	cSt at 20 °C	cSt at 37.8 °C	cSt at 50 °C	cSt at 20 °C	cSt at 37.8 °C	cSt at 50 °C
ISOVG2	1.98-2.42	(2.82-3.67)	(2.05-2.52)	(1.69-2.03)	(2.87-3.69)	(2.05-2.52)	(1.69-2.03)	(2.92-3.71)	(2.06-2.52)	(1.69-2.03)
ISOVG3	2.88-3.52	(4.60-5.99)	(3.02-3.71)	(2.37-2.83)	(4.59-5.92)	(3.02-3.70)	(2.38-2.84)	(4.58-5.83)	(3.01-3.69)	(2.39-2.86)
ISOVG5	4.14-5.06	(7.39-9.60)	(4.38-5.38)	(3.27-3.91)	(7.25-9.35)	(4.37-5.37)	(3.29-3.95)	(7.09-9.03)	(4.36-5.35)	(3.32-3.99)
ISOVG7	6.12-7.48	(12.3-16.0)	(6.55-8.05)	(4.63-5.52)	(11.9-15.3)	(6.52-8.01)	(4.68-5.61)	(11.4-14.4)	(6.50-7.98)	(4.76-5.72)
ISOVG10	9.00-11.0	20.2-25.9	9.73-12.0	6.53-7.83	19.1-24.5	9.68-11.9	6.65-7.99	18.1-23.1	9.64-11.8	6.78-8.14
ISOVG15	135-16.5	33.5-43.0	14.7-18.1	9.43-11.3	31.6-40.6	14.7-18.0	9.62-11.5	29.8-38.3	14.6-17.9	9.80-11.8
ISOVG22	19.8-24.2	54.2-69.8	21.8-26.8	13.3-16.0	51.0-65.8	21.7-26.6	13.6-16.3	48.0-61.7	21.6-26.5	13.9-16.6
ISOVG32	28.8-35.2	87.7-115	32.0-39.4	18.6-22.2	82.6-108	31.9-39.2	19.0-22.6	76.9-98.7	31.7-38.9	19.4-23.3
ISOVG46	41.4-50.6	144-189	46.6-57.4	25.5-30.3	133-172	46.3-56.9	26.1-31.3	120-153	45.9-56.3	27.0-32.5
ISOVG68	61.2-74.8	242-315	69.8-85.8	35.9-42.8	219-283	69.2-85.0	37.1-44.4	193-244	68.4-83.9	38.7-46.6
ISOVG100	90.0-110	402-520	104-127	50.4-60.3	356-454	103-126	52.4-63.0	303-383	101-124	55.3-66.6
ISOVG150	135-165	672-862	157-194	72.5-86.9	583-743	155-191	75.9-91.2	486-614	153-188	80.6-97.1
ISOVG220	198-242	1080-1390	233-286	102-123	927-1180	230-282	108-129	761-964	226-277	115-138
ISOVG320	288-352	1720-2210	341-419	144-172	1460-1870	337-414	151-182	1180-1500	331-406	163-196
ISOVG460	414-506	2700-2210	495-608	199-239	2290-2930	488-599	210-252	1810-2300	478-587	228-274
ISOVG680	612-748	4420-5680	739-908	283-339	3700-4740	728-894	300-360	2880-3650	712-874	326-393
ISOVG1000	900-1100	7170-9230	1100-1350	400-479	5960-7640	1080-1330	425-509	4550-5780	1050-1290	466-560
ISOVG1500	1350-1650	11900-15400	1600-2040	575-688	9850-12600	1640-2010	613-734	7390-9400	1590-1960	676-812

Between 0 to 15°C oil is too thick, and pump may not be able to suck oil, which will lead to cavitations. Between 15°C to 20°C hydraulic system will work but with sluggish motion and low efficiency. We get best result between 30°C to 50°C temperature. At this range oil life is also optimum. Above this temperature with every 8°C rise in temperature, working life of oil decreases by 50%. Between 50°C to 70°C system could be operated using cooler to control oil temperature. Between 70° to 80°C is sub-critical temperature and not recommended to operate system, above 80°C is critical temperature at which system should never be operated.

### 5.10. Specification of Hydraulic Oil Generally Specified by Oil Manufacturers: -

This detail will give you idea about what oil manufacture specify about their product.

#### Characteristics Table

Sr. No.	Characteristics	Trade-Name		
		xxxx-32	xxxx-146	xxxx-168
1	Kinematics Viscosity cSt @ 40°C @ 100°C	32.6	47.6	67.9
		5.5	7.1	8.7
2	Viscosity Index	101	100	98
3	Flash Point COC °C	190	220	240
4	Pour Point °C	-9	-9	-9
5	FZG pass Load Stage	10	10	10
6	Copper Corrosion @100°	1	1	1
7	Rust Test (ASTM D665,24 hrs)	Pass	Pass	Pass
8	Vickers v-1040 Vane pump set (D-2882) Wear, mg	50	50	50

XXX : Will be trade name of manufacturer.

## Chapter - 6

# FLUID CONDUCTOR

### 6.1 Importance of fluid conductor: -

Fluid conductors are like blood vessels of hydraulic system, if selected and used correctly then system will give performance as per desired requirement. And, if not selected or used correctly, then it will lead to cavitation, excessive pressure drop, oil heating, leakage, difficulties in maintenance, and over-all inefficient performance. Hence fluid pipe lines should be designed and implemented correctly for a maintenance free and efficient hydraulic system.

### 6.2 Criteria of Selection of Fluid Conductor: -

The function of fluid conductor is to,

1. To carry the fluid efficiently.
2. To withstand internal pressure.

To carry fluid efficiently, it is necessary to keep pressure losses to a minimum. When a fluid flows through a fluid conductor heat is generated by friction. The part of energy, which is lost as heat energy, results in a pressure loss.

These pressure losses depend upon,

- i. Flow velocity. (at higher velocity pressure loss is more)
- ii. Length of fluid conductor, (pressure drop is more if length is more.)
- iii. The viscosity of the fluid flowing. (higher the viscosity higher is resistance to flow and more pressure losses)
- iv. The type of flow (Laminar or Turbulent) (in Turbulent flow pressure losses are more)

#### 6.2.1 Type of Flow: -

There are two types of flows namely Laminar flow & Turbulent flow. In laminar flow the individual fluid particle moves up to certain speeds in uniform layers along side each other, and do not disturb or influence each other. While in Turbulent flow, the flow becomes whirling and turbulent. The individual particles no longer move in one direction in orderly fashion, but influence and hinder each other.

In turbulent flow there is more loss of energy and pressure drop. The type of flow changes from laminar to turbulent at certain flow velocity. This velocity is given by the Reynolds's number.

For cylindrical flow lines the following formula applies.

$$Re = V \times d / \nu$$

V = velocity (m/s)

d = fluid conductor inside diameter (m)

$\nu$  = Kinematics viscosity ( $m^2/s$ )

When value of Re exceeds 2300 flow becomes turbulent.

When it is practically not possible to have velocity exactly as per Renold's formula for laminar flow. Following fluid flow velocities have proved to be most suitable for hydraulic fluid lines.

Recommended flow velocities: -

- i. Suction lines : 0.6 to 1.6 m/sec.
- ii. Exhaust or Return line : 1.6 to 3.0 m/sec.
- iii. Pressure line : 3.0 to 4.5 m/sec.
- iv. Short pressure line : 4.5 to 6.0 m/sec.

It is therefore important to calculate correctly the required fluid conductor size. Under size pressure line results in high fluid velocity causing an excessive pressure drops, and heat build-up, which impair over-all system performance. Under size suction line can cause cavitation at the hydraulic pump inlet, affecting performance, reducing pump life, increasing sound level.

The pump discharge is known for a given system. We can assume velocity for a given pipe line as described above. On basis of above two known factors, inside diameter of fluid conductor can be calculated using following equation.

$$A \times V = G$$

A = Cross-section of conductor (m<sup>2</sup>).

V = Flow velocity of fluid (m/sec)

G = Discharge of pump (m<sup>3</sup>/sec).

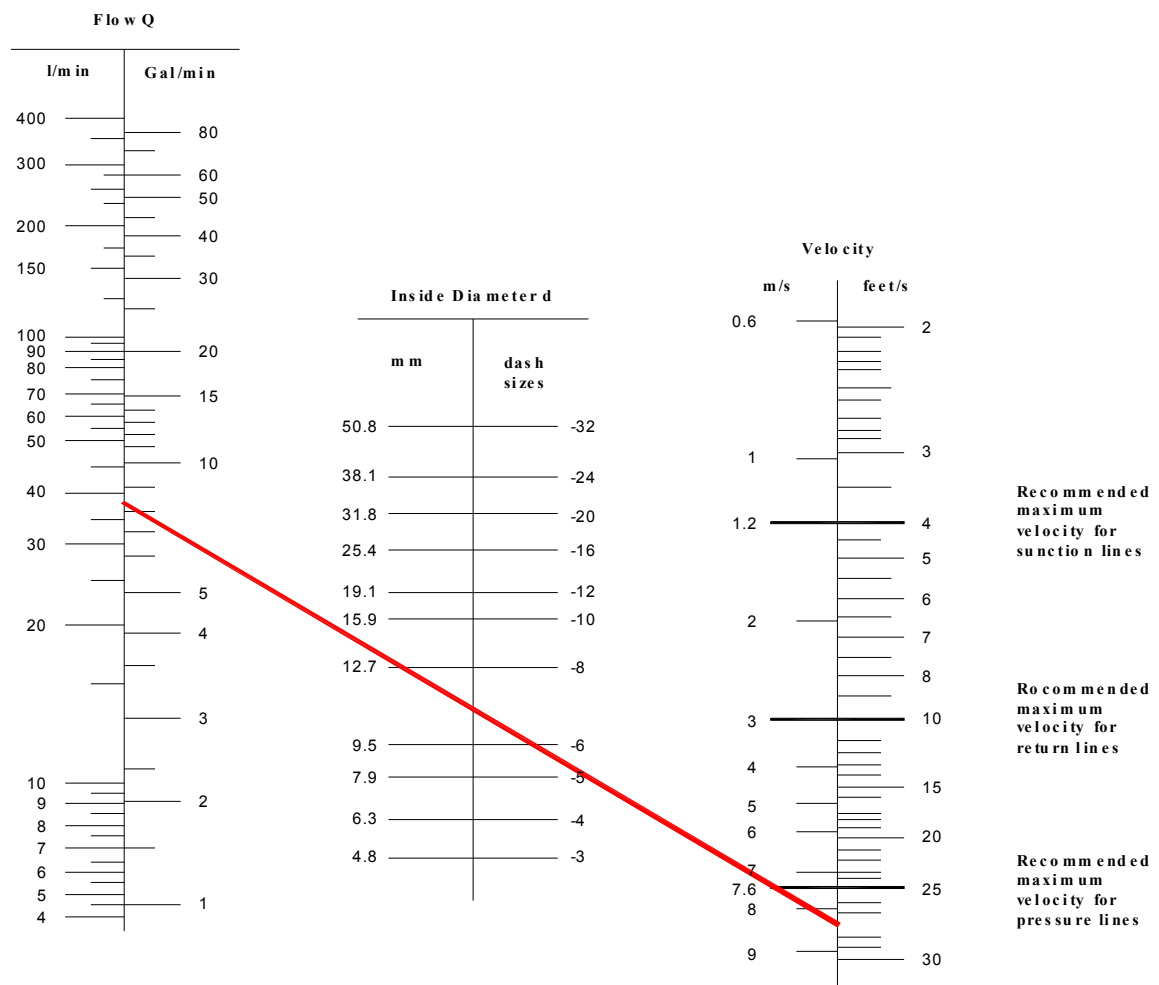

For convenience monograph could be used for calculating third factor if any two are known.

## Types of Fluid Conductor: -

There are three types of fluid conductor in industrial hydraulic system, namely.

1. Manifold blocks.
2. Pipes & Tubes.
3. Hoses.

### 6.3 Manifold Blocks :-

Interconnecting hydraulic element by manifold block is most desired method. In this the oil passage is made by drilling holes in solid metal block between two hydraulic element mounted on it. It make system neat and compact. But manifold block has its limitation. It has to be supplemented by pipes and hoses, as drive (motor/pump), control (valves), actuator (cylinder), need not be very close to manifold but are placed at distance, as per requirement of system.

There are three types of manifold blocks.

- i. Unit-Manifold block with stacked valves.
- ii. Manifold blocks with integrated circuit.
- iii. Gasket-Mounted Manifold Blocks.

#### 6.3.1 Unit-Manifold Blocks with Stacked Valves: -

When circuits are simple, and modular types standard valves are available, which can fulfil the requirement of a hydraulic cylinder and give satisfactory performance, then these types of manifold blocks are used.

These are simple types of manifold blocks, which actually acts as a junction, at which pump line, exhaust line and cylinder port lines end and connected to various modular valves stacked on it. As it only act as sub-plate to various valves hence it is also referred as “single or multiple station sub-plate”.

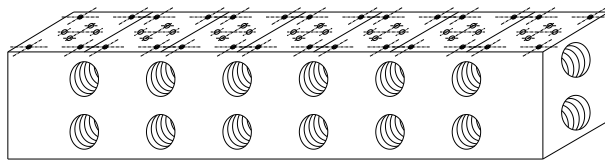
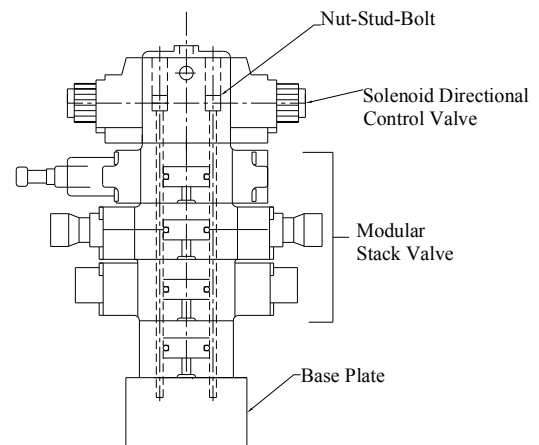

Figure 6.2 Unit Manifold Block



(Manifold Block shown in side view)  
Figure 6.3 Multi Station Sub-Plate

### 6.3.2. Manifold Block with Integrated Circuit: -

When requirement of circuits are more complex and standard modular valves are not available or not rated for said requirement, then this types of manifold blocks are used. These blocks are machined from a solid block of metal in which some functions are machined right into the blocks, some added as cartridges and other mounted on it. Advantage includes, improved response time and reduces pressure drop. More function can be incorporated in this type of manifold block as compared to any other type.

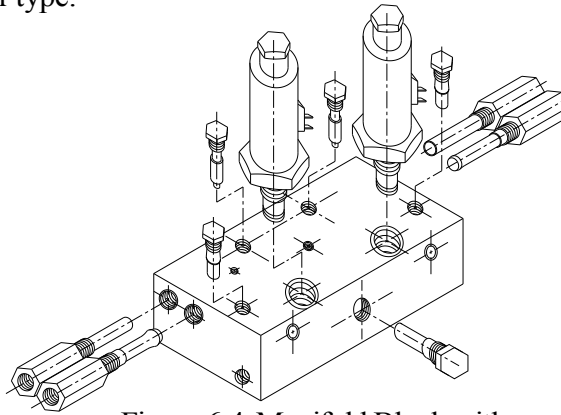

Figure 6.4 Manifold Block with Integrated Circuit fitted with Cartridge Valve

### 6.3.3 Gasket Mounted Manifold Block: -

In this type of manifold, individual valves are mounted on a common sub-plate, which are interconnected to each other by various passages made on the other secondary plates. Then all plates are fixed together by means of static-o-ring or gaskets. Because of size and weight 8 to 9 functions can be incorporated in this type of manifold. These type blocks are also called manifold panel. First two types of manifold blocks are only in common uses nowadays.

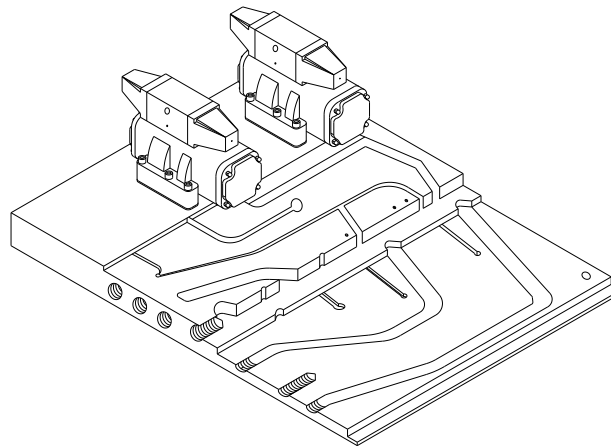

Figure 6.5 Gasket Moulded Manifold Block

## 6.4 Pipes & Tubes: -

### 6.4.1 Pipes: -

Pipes are rigid fluid conductors, it is preferred when,

- Large volume of fluid is to be handled,

- Where the line is long and straight.
- Where disassemble is improbable or very infrequent.
- Where threading type of end-connection is to be used.

Pipes are made from, copper, brass, stainless steel, carbon steel etc. but nowadays mostly seamless pipes of carbon steels are used.

As pipes are threaded for making threaded joints, hence their out-side diameter is as per the dimensions required for making pipe threads. For example ½” nominal bore pipe will have 21.3mm out-side diameter, so that said out-side diameter could be easily machined to make ½ BSP threading.

Wall thickness of pipe depends upon the internal pressure of fluid passing through it. For higher pressure required wall thickness is more. As out side diameter of pipe cannot be changed for making pipe threading, hence ID of pipe changes with change in wall thickness.

For standardization ASTM has specified various nominal bore diameter of pipe such as NB 1/8, ¼, 3/8, ½, 5/8, ¾, 1", 2", 3", ..... 24". ASTM has also specified 10 standard thicknesses for each nominal bore size of pipe. These standard thick nesses are called **schedules**. These ten schedules are 10, 20, 30, 40, 60, 80, 100, 120, 140, and 160. In industrial hydraulic system we generally use only three schedules namely 40, 80 and 160. Pipes of schedule 40 are used for low-pressure, schedule, 80 for medium-pressure, and schedule 160 for high-pressure applications. For further detail refer ASTM table in chapter on “Design of Hydraulic Cylinder.

#### 6.4.2 Tubes: -

Tubes are semi-rigid fluid conductors, made from copper, brass, aluminum, stainless steel, plastic, PTFE and carbon steel. But in industrial hydraulic generally carbon-steel tubes are used. Tubes could be easily bent, swaged or flared. Simple types of end-fittings are also available for tubes hence piping are simple, neat, clean and easy in maintenance when tubing are used.

In case of tube also outside diameter is fixed, and inside diameter changes with increase in wall thickness.

#### 6.5 End-fitting of Pipes & Tubes: -

Pipes and tubes are connected to corresponding part by means of pipe-end fitting. End-fittings of pipes and tubes could be classified in two categories namely.

1. Metal fitting for high pressure and temperature.
2. Plastic fitting for low pressure.

Generally metal fittings are used with metal tubes and plastic fitting with plastic tubes.

##### 1. Metal Fitting: -

Metal fitting can be further divide into two categories.

- a) Separable End-fittings.
- b) Permanent End-fittings.

**Separable End-fittings** are those fittings, which can be separated from tube easily and could be replaced without any preparation or operation. **Permanent End-fittings** are those fittings,

which are welded to tubes, and cannot be removed without cutting it. In general for high pressure, high volume of oil flow, and tube of thick wall thickness permanent type of fittings are used. For medium pressure, medium flow separable end-fittings are used.

### 6.5.1 Separable End-fittings: -

There are many types of separable end-fittings available in industry, but we will discuss only few types, which are in more common use.

#### i. Ferrule type compression fittings: -

It consists of a male stud coupling, a ferrule and a nut. The body end of male stud coupling is screwed into the body. For sealing, copper or dowty washer, or Teflon tapes are used at body-coupling interface. While at coupling-tube interface sealing is due to biting action of the ferrule on the tube. The ferrule is forced into the conical portion of the coupling by the nut, thereby causing its sealing edge to bite into the tube in order to take the hydraulic load and to prevent the leakage along the tube.

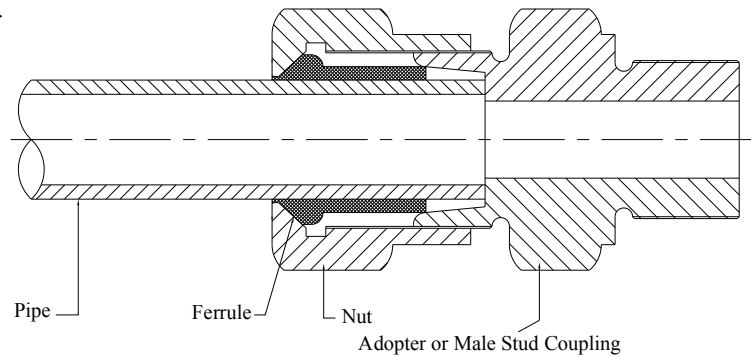

Figure No. 6.6 Ferrule Type Cmpression

#### ii. Threaded flare fittings: -

It consists of a male stud coupling a sleeve and a nut. For using this type of coupling, end of tube is to be flared, at  $37^\circ$  or  $45^\circ$ . The sealing action at male stud coupling and tube interface is achieved by pressing flared end of tube between sleeve and male stud coupling as shown in following sketch.

As special flaring operation is required for using this type of fitting, and steel tubes are difficult to flare hence ferrule type compression fittings are more in use than this type of coupling in industry.

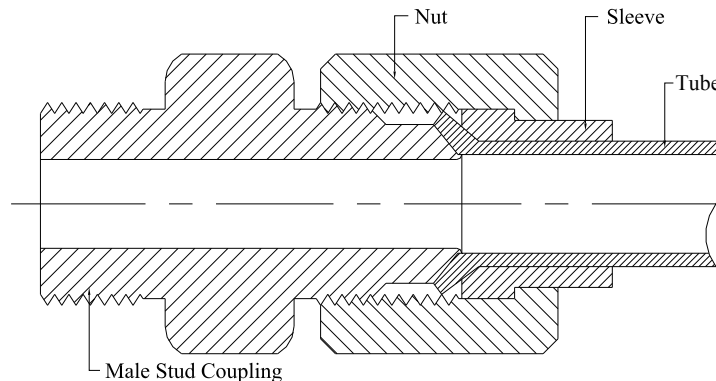

Figure No. 6.7 Threaded Flared Fitting



### 6.5.2 Permanent End-Fittings: -

Permanent End-fittings are of two types.

- i. Flange type weldable end fitting.
- ii. Threaded type weldable end fitting.

#### i. Flange type Weldable End-Fitting: -

In these types of end fittings flanges are welded to tube, which are bolted to body. For oil sealing gasket or o-rings are used along with flange.

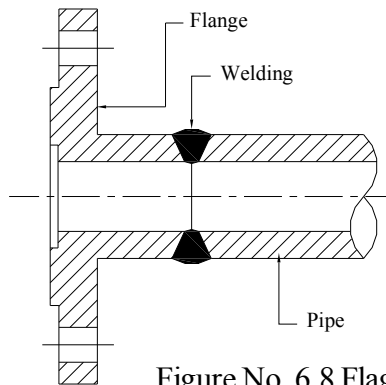

Figure No. 6.8 Flag Type Welded End Fittings

#### ii. Threaded type Weldable End-Fitting: -

These types of end fitting consist of a male-stud-coupling, a poppet and a nut. Poppet is welded to pipe. Sealing face of poppet may have groove to accommodate o-ring or taper or convex smooth machined surface matching to corresponding smooth machined seat in male-stud-coupling.

Sealing action between male-stud-coupling and poppet is achieved by forcing sealing face of poppet against sealing face of male-stud-coupling.

Weldable type end fitting are difficult to use as it require tube end preparation, welding skill, and cleaning and chipping etc. But it has advantage that it can be used for high pressure, high volume of oil flow, and in those condition in which hydraulic system could be subjected to misuse. Most important factor in selection of this type of fitting is there “anti-blow-off-feature”. That is pipe do not slip out from pipe end fitting under pressure. Such slipping out of pipe from fitting is very dangerous, and can even cause serious injury to the operator.

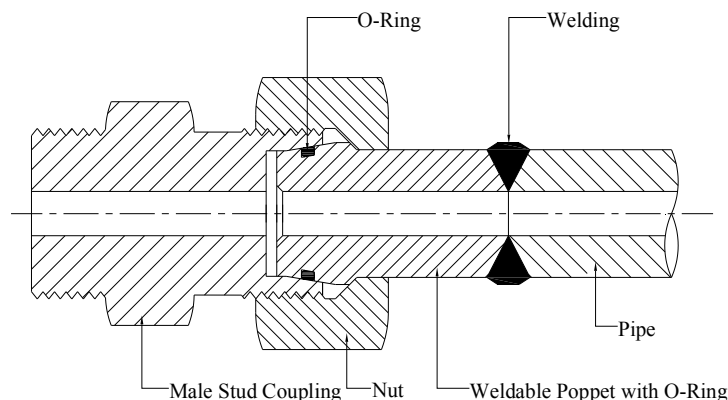

Figure No. 6.9 Threaded Type Welded End Fittings

## 6.6 Anti-Blow-off-Feature: -

Fluid conductor and pipe end fitting withstands three types of load.

- i. Direct pulling-out force developed due to pressure developed in fluid conductor. This fluid force is equal to internal cross section area multiplied by working pressure. This force is more pronounced when one end of conductor is blocked.
- ii. All the fluid conductor if they have bends and curvatures try to straighten when pressurized. It exerts too much bending load on joints.
- iii. Miss-use of fluid-conductor and wrong assembly also develops unnecessary load in it. For example, if the two ends of bend-pipe are slightly mismatching the corresponding connection point, it could be matched forcefully, but this will also apply additional load on joint. If a fluid conductor is also used for other purpose such as any mechanical load taking member of machine along with its basic function of fluid conductor then also too much load comes on joint.

Cylinder, fluid conductor and accumulator etc., when pressurized are like a bomb. Pressurized fluids, if released uncontrolled, can exert a tremendous explosive force. If these components explode then metallic pieces of cylinder and accumulator, and uncontrolled swing of hydraulic pipeline can cause excessive damage to property and severe injury or death to human being.

Hence utmost precaution must be taken while working with system and machine working on high-pressure fluid. End connection of fluid-conductor should be such that all the three types of loads mentioned above should not cause failure to the end fitting. When end-fittings fail under pressure, the pipeline gets detached from end-fittings, it tries to straighten and swings with tremendous force. This process is called “Blowing off of fluid line”. Author of this book has seen death of machine operator due to such end-fitting failure and swing of pipeline, in a fabrication and construction company.

## 6.7 Material of End-fittings: -

End-fittings could be made from carbon steel, brass, stainless steel or monel material depending upon the fluid to be handled and the environment. But most suitable material for hydraulic fittings and hose-end fittings is EN1A, which is a plain carbon free cutting steel, for detail about this material refer to chapter “Material Used in Hydraulic Presses”.

## 6.8 Hoses: -

Third types of fluid conductors are hoses. These are used when pipeline must flex, or bend in operation.

A hose consists of,

- (a) “Inner tube”, which is a seamless tube of oil resistance material, it confines the fluid in hose pipe.
- (b) Intermediate “reinforcement” of textile, rayon or steel wire etc., this part of hose withstands the fluid pressure, and supports the inner seamless tube.
- (c) “Outer covering” of oil and weather resistance material. This protects the reinforcement against corrosion, abrasion, and other type of damages.

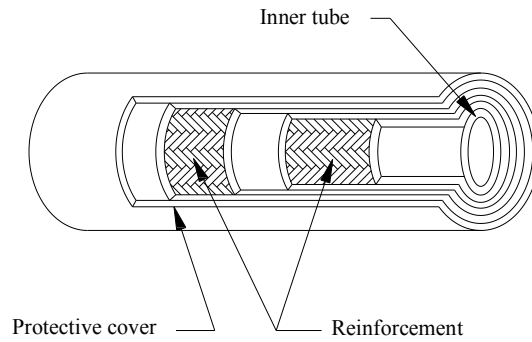

Figure No. 6.10 Hose Pipe

## 6.9 Factor Considered while Selecting a Hose: -

There are forty types of hoses for various applications and working conditions, for selecting a hose out of so many grades is very difficult. We are listing some outlines, which could be considered while selecting a hose.

### (i) Pressure and pressure impulse: -

Hoses are pressure tested, testing pressure of hose is double the working pressure. And the bursting pressure of hoses are double the test pressure. Hence recommended working pressure of hose is 25% of burst pressure.

Hoses are also impulse tested at 100% to 130% of rated pressure. Various grades of hoses are made for low to very high pressure and impulses. As per the pressure requirement of system hoses should be selected.

### (ii) Temperature: -

Hose withstands internal fluid temperature and external ambient temperature. Hoses are available with different types of material to give satisfactory performance in broad range of temperature. Hoses with flame-resistance outer covering is also available. Hoses should be selected as per ranges of working temperature.

### (iii) Size: -

If the fluid velocity is high in fluid conductor the flow will be turbulent and energy will be lost. Hence correct size of hose should be selected for laminar flow. The equations, which are used for pipe to calculate inside diameter, can also be used for hose to find its ID. In case of pipe and tube, as thickness increases, OD remains same and ID decreases. While in case of hose pipe, as thickness increases ID remains same and OD increases.

### (iv) Reinforcement type: -

The reinforcement may be a natural yarn or fiber, a metal wire or combination. The reinforcement may be braided or spiral wound or both.

Spiral wire wound hoses are often used for applications with high frequency surges in high-pressure systems. As pressure surges in normal braided reinforced hoses, they tend to fail at the wire crossover point in the weave. These points cause bending and shear in wires that are already highly stressed. The advantage of spiral wire reinforcement is that it eliminates crossover points permitting up to 97% of the theoretical total coverage. Hence reinforcement should be selected as per applications and pressure of hose.

**(v) Fluid Compatibility: -**

Most of the hoses are made from material, which are compatible with most of the hydraulic fluid. Hoses are also available with PTFE internal lining or stainless steel bellows, for handling chemical fluid. Select hose whose materials are compatible with working fluid.

**6.10 Classification of Hoses: -**

Hoses have not developed in an orderly fashion; rather they developed in response to market demands, advances in manufacturing technique, development and availability of new hose material etc. Hence there are so many varieties of hoses with different material and reinforcement with similar characteristics. As a result, sorting through hoses designations and capabilities become a formidable task. Society of automotive engineers (SAE) has established standards for hoses. They have made various categories depending upon material of reinforcement type of reinforcement; type of internal sleeve and out side protection covering. For each category they have described working pressure, test pressure, burst pressure, range of working temperature and hose size etc.

In following paragraph we will discuss some of the category related to construction of hose and then a summery table related to pressure, as per SAE standard.

**6.10.1 Classification of Hoses as per SAE Standard: -**

- (a) 100 R1A : One-wire-braid reinforcement, with synthetic rubber cover. (Inside synthetic rubber oil resistant sleeve remain same in all grade of hoses.)
- (b) 100 R1T : Same as R1A except with a thin, non-skive cover.
- (c) 100 R2A : Two-wire-braid reinforcement, with synthetic rubber cover.
- (d) 100 R2B : Two spiral wire plus one wire-braid reinforcement, with synthetic rubber cover.
- (e) 100 RAT : Same as R2A except with a thin, non-skive cover.
- (f) 100 R2BT : Same as R2B except with a thin, non-skive cover.
- (g) 100 R3 : Two-textile-braid reinforcement, with synthetic rubber cover.
- (h) 100 R4 : One or more woven or braided textile layers and one spiral-wire layer, with synthetic rubber cover.
- (i) 100 R5 : One-textile-braid plus one-wire-braid reinforcement, with textile-braid cover.
- (j) 100 R6 : One-textile-braid, with synthetic rubber cover.
- (k) 100 R7 : Thermoplastic tube, synthetic fiber reinforcement, thermoplastic cover (thermoplastic equivalent to SAE 100R1A).
- (l) 100 R8 : Thermoplastic tube, synthetic fiber reinforcement, thermoplastic cover (thermoplastic equivalent to SAE 100R2A).
- (m) 100 R9 : Four-ply, light-spiral-wire a thin, reinforcement, synthetic rubber cover.
- (n) 100 R9T : Same as R9 Except with a thin, non-skive cover.
- (o) 100 R10 : Four-ply, heavy-spiral-wire reinforcement, synthetic rubber cover.
- (p) 100 R11 : Six-ply, heavy-spiral-wire reinforcement, synthetic rubber cover.
- (q) 100 R12 : Four-ply, heavy-spiral-wire, synthetic rubber cover.
- (r) 100 R13 : Four or six layers of spirally wrapped high tensile steel wire reinforcement separated by synthetic rubber cushion on a fabric layer, synthetic rubber outer cover.
- (s) 100 R15 : Synthetic rubber tube, four to six layers of spirally wrapped high tensile steel wire reinforcement. Separated by synthetic rubber cushion on a fabric lager, synthetic rubber outer-cover.

### 6.10.2 Hose Pressure Rating :-

SAE Designation	Maximum operating pressure for indicated hose ID (psi)										
	3/16 in.	¼ in.	5/16 in.	3/8 in.	½ in.	5/8 in.	¾ in.	1 in.	1 ¼ in.	1 ½ in.	2 in.
100R1	3,000	2,750	2,500	2,250	2,000	1,500	1,250	1,000	625	500	375
100R2	5,000	5,000	4,250	4,000	3,500	2,750	2,250	2,000	1,625	1,250	1,125
100R3	1,500	1,250	1,200	1,125	1,000	875	750	565	375	-	-
100R4	-	-	-	-	-	-	300	250	200	150	100
100R5	3,000	3,000	2,500	2,000	1,750	1,500	-	800	625	500	350
100R6	500	400	400	400	400	350	-	-	-	-	-
100R7	3,000	2,750	2,500	2,250	2,000	1,500	1,250	1,000	-	-	-
100R8	5,000	5,000	-	4,000	3,500	2,750	2,250	2,000	-	-	-
100R9	-	-	-	4,500	4,000	-	3,000	3,000	2,500	2,000	2,000
100R10	10,000	8,750	-	7,500	6,250	-	5,000	4,000	3,000	2,500	2,500
100R11	12,500	11,250	-	10,000	7,500	-	6,250	5,000	3,500	3,000	3,000
100R12	-	-	-	4,000	4,000	-	4,000	4,000	3,000	2,500	2,500
100R13	-	-	-	-	-	5000	5000	5000	5000	5000	5000
100R15	-	-	-	-	-	-	6000	6000	6000	6000	-

In above paragraph, we have described only few grades of hoses described by SAE, while most of the hose manufactures generally manufacture more than forty varieties of hoses. For more knowledge on hoses refer to the products catalogue of hose manufacturers

In following paragraph we will again summaries six type of hoses, which are widely used in industry, and cover all the range of pressure.

#### One Wire Braid Hose :-

These are made as per SAE 100R1 specification and commonly known as R1 hoses. It consists of a synthetic rubber tube, single high tensile steel wire braid reinforcement, and synthetic rubber outer-cover.

These are used for **low to medium pressure applications.**

#### Two Wire Braid Hose: -

These are made as per SAE 100R2. And commonly known as R2 hoses. It is made of synthetic rubber oil resistant tube, two high tensile steel wire braids reinforcement separated by synthetic rubber layer, and oil, fuel, weather, ozone and abrasion resistance synthetic rubber outer-cover.

These are used for **medium to high-pressure applications.**

#### Four Wire Spiral Hose: -

These are made as per SAE J517 R9, DIN 20023 4SP, DIN 20023 4SH. It is made from oil resistant synthetic rubber tube, four layers of spirally wrapped high tensile steel wire reinforcement separable by synthetic rubber over a fabric layer, and synthetic rubber outer cover which is oil, fuel weather, ozone and abrasion resistant.

These types of hoses are used for **high-pressure pulsating pressure application.**

#### Six Wire Spiral Hose: -

These are made as per SAE J517 R13 & SAE J517 R15 specification. It is made from synthetic rubber tube. Four to six layers of spirally wrapped high tensile steel wire rubber cushion on a fabric layer, synthetic rubber outer cover.

These hoses have highest pressure rating, and used for **extremely high pulsating pressure services.**

## 6.11 Type of Hose End-fittings: -

There are two types of hose end-fittings.

- i. Reusable Type.
- ii. Permanently Attached Type.

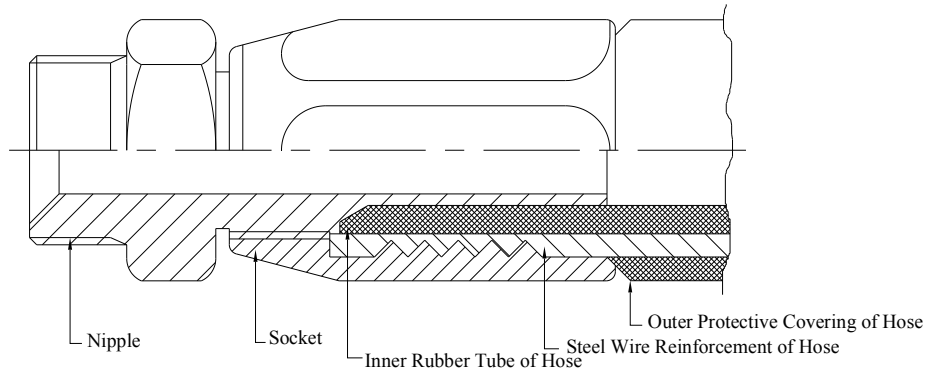

Figure No. 6.11 Re-usabile Type of End Fitting

Reusable types of fittings could be removed from failed hose and could be used again in new hose. Reusable fittings could be thread type or bolted type. But threaded type is widely used. It consists of a nipple having fine and taper threads and a socket have female coarse thread. First socket is screwed on hose out side diameter, and then nipple is screwed in ID of hose. Nipple has tapering diameter hence it enters easily but at the end force has to be applied to tighten it, which also proved sealing force.

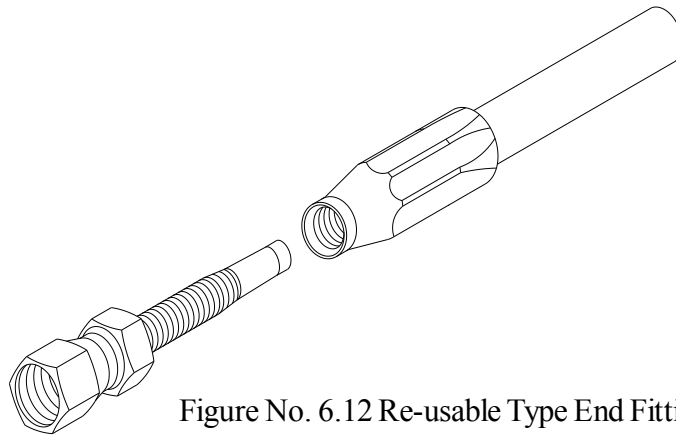

Figure No. 6.12 Re-usable Type End Fitting

Permanently attached type of end fittings also has nipple and socket. Nipple is fitted in ID of hose, socket on OD of hose. To hold hose firmly between nipple and socket, socket squeezed on to the hose. This squeezing of hose is called **crimping or swaging**. Outer rubber protective cover of hose is removed before crimping, The process cover removing is Called **skiving**. Both nipple and socket have special type of grooves to hold hose against slipping out. In case of high pressure hoses the steel wire reinforcement is inter locked between sleeve and nipple for higher resistance against slipping-off.

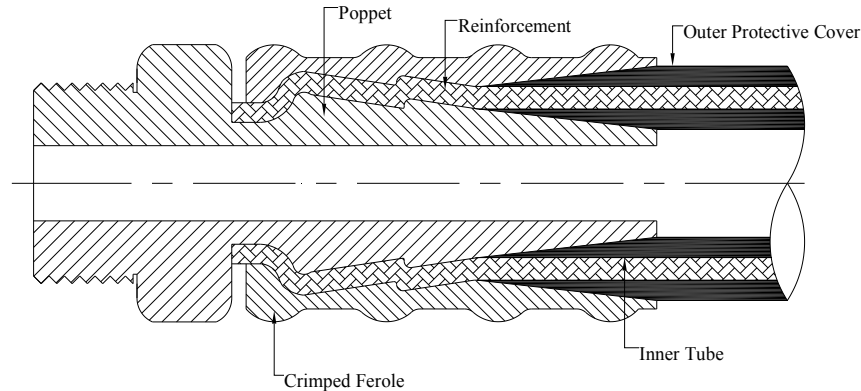

Figure No. 6.13 Permanently attached type End-Fitting

Once hose fail the end-fitting has to discarded as it cannot be re-used. Socket squeezing operation, which is commonly known as “crimping” is done on a special hydraulic machine, called “Hose Crimping Machine”.

## 6.12 Material of End-fittings: -

End-fittings could be made from carbon steel, brass, stainless steel or monel material depending upon the fluid to be handles and the environment. For general purpose industrial hydraulic applications end-fitting are made from EN1A, which is a free cutting low carbon steel.

## 6.13 Common causes of End-fitting leakage in Pipe and Hoses: -

### i. Human Error: -

If fitter forget to tighten the fitting or if he over-tighten it, then joint will leak, Over tightening result in cracking of Nut & Nipple.

### ii. Lack of Quality Control: -

Selection of soft material, chattering or machining mark on seat of nipple will result in leakage. Soft material yields and joint get looses.

### iii. Poor Protection of Fitting in Handling: -

This results in damage of seat and sticking of dust particles on seat, which result in leakage.

### iv. Lack of Training: -

If operator has less experience then he may use fitting with different standard of threading or he may fix fluid conductor incorrectly which result in leakage.

### v. Improper design of system: -

If fluid conductors are difficult to assemble, and once assemble then difficult to check and tighten then such system are difficult to maintain and in long run will leak and give problem.

## 6.14 Installation and Fixing of Hose Pipe: -

Before using hose pipe, first design and plan how to route it.

- i. It should be routed in such a way that no bending load come between end-fittings and hose.
- ii. Hoses elongate up to 2% or contract up to 4% when pressurized depending upon type, size and pressure. Hence length should be always more than 4% then required.
- iii. Hoses never should get twisted, twisting force can reduce hose life up to 70%. Name of manufacturer, date of manufacturing, ID of hose, maximum working pressure and grade of hose continuously printed on hose in straight line, which is referred in industry as “**lay line**”. This lay-line gives good judgement, if hose get twisted.
- iv. Hoses should not cross each other or touch any object while flexing and bending. As this erode (wear-out) the outer-rubber-protection covering. If outer-cover get eroded, steel-wire of reinforcement get exposed, which get corroded due to moisture and get weaken and result in early failure of hose.
- v. Hoses are sensitive to heat and cold. If they cross over any pipeline in a plant, which are hot or cold, then protective guard should be provided between hose and that pipeline.
- vi. Hoses are heavy in weight when they are filled with oil. End-connections are not design for pulling load. If hoses hang-freely, then on-weight of hose give a pulling load on end-fitting, which result in an early failure. Hence in such case it should be supported to avoid any pulling load on end-connection.
- vii. Select right type of end-fittings and adopter. It will make piping more heat and accessible. For example a bend-adopter in end-connection can reduce their long bend in hose.
- viii. Due to change in length when hose is pressurized, do not clamp at bends so curves absorb changes in length Do not clamp high-pressure and low-pressure hose together as their expansion and contractions are difficult.

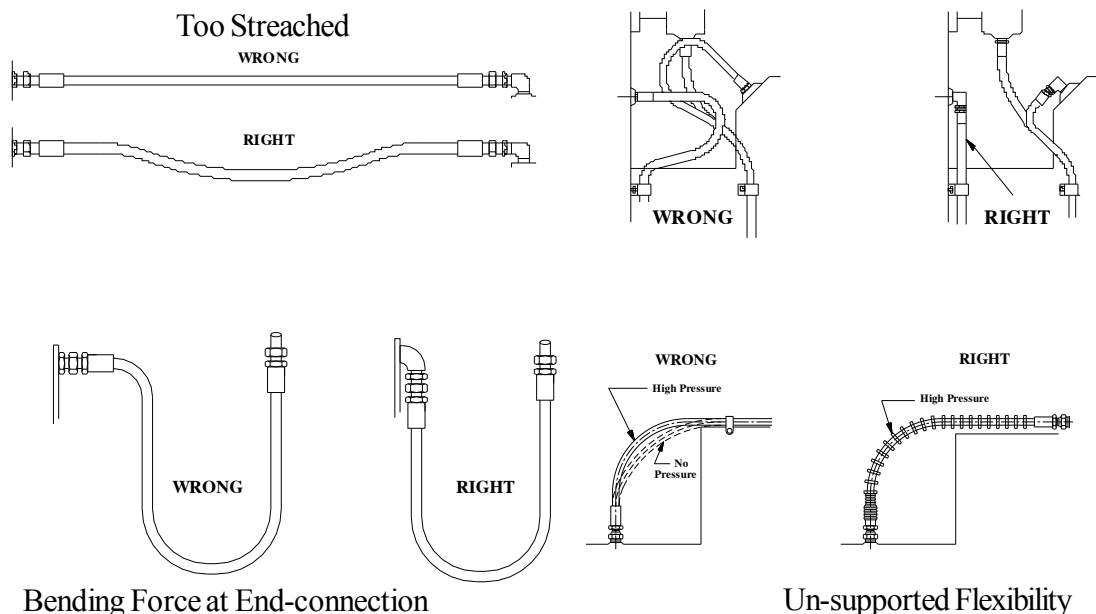



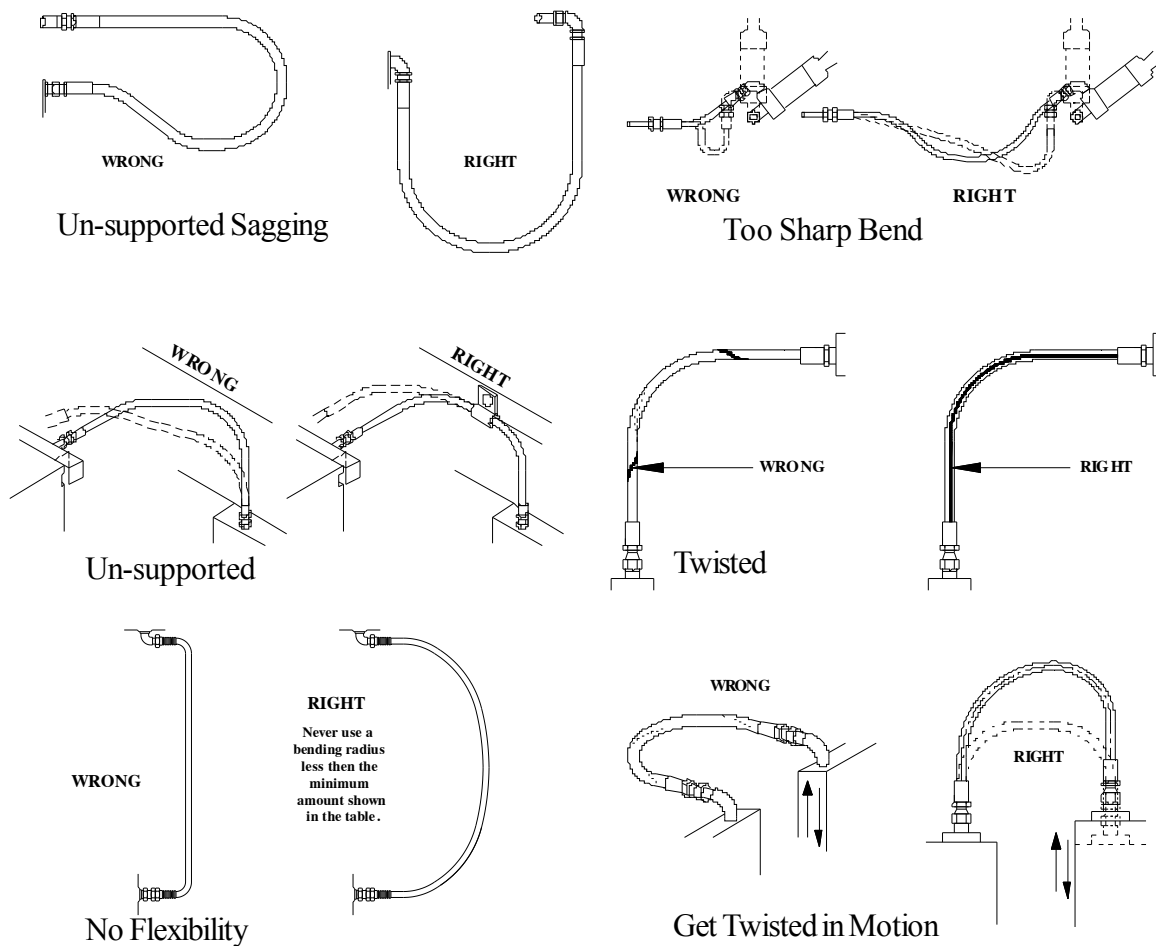

### 6.15 Common Problem of Hoses, and their cause and remedies :-

- i. Problem :-** A spiral reinforcement hose has burst and split open, with wires bulging out and badly entangled.
- Cause :-** The hose length too short to accommodate approximately 4% contraction while pressurized.
- Remedies :-** Always keep some extra length for contraction.
- ii. Problem :-** Hose has burst and examination of wire reinforcement after stripping back the outer cover reveals random broken wires on the entire length of the hose.
- Cause :-** In case of braided-steel-wire-reinforcement, wire criss-cross each other, under pressure they get bending and shear load. If the system has high-frequency pressure impulse then wire get worn-out on this cross point, reinforcement weakens and hoses fail.
- Remedies :-** Spiral reinforcement hose should be used in such case.
- iii. Problem :-** The hose has burst but there is no sign of multiple broken wire on the entire length of hose.
- Cause :-** This indicates that the pressure has exceeded the minimum burst strength of the hose, either due to selection of low rating hose or malfunctioning of pressure relief valve resulting surge of pressure.

- Remedies :-** Check system pressure and hose rating, and hose accordingly.
- iv. Problem :-** The hose liner is hard and has cracked.
- Cause :-** Heat has a tendency to leak the plasticizers out of the material of inner liner. Plasticizer gives the hose its flexibility or plasticity. Situations get worse when oil is aerated. Oxygen in air causes oxidation, and hardening of material. Heat and oxygen accelerate the hardening process and hose liner crack under pressure. Cavitations also have same effect on liner.
- Remedies :-** Temperature of oil should be below 50°C and in no case about 70°C. oil should not be aerated.
- v. Problem :-** The hose is cracked both externally and internally, but the both inner and outer elastomeric materials are flexible at room temperature.
- Cause :-** The cause may be that hose has been used in extremely cold condition. At low temperature elastomeric material loses their flexibility and cracked if flexed.
- Remedies :-** Use those grade of hoses which are designed for extremely low temperature.
- vi. Problem :-** Hose is flattened out in burst area. The inner tube is hard in down stream of the burst but appears normal upstream of the burst.
- Cause :-** When hose is bend in too short radius it kinks or collapses at the bend. When such bend burst it flatten-out. Kinking produces restriction in oil flow push causing high velocity of oil and heating down stream of kink cause hardening of hose.
- Remedies :-** Avoid short bend and collapsing of hose.
- vii. Problem :-** The hose has burst about 6 to 8 inches away from end-fittings. Reinforcement rusted but outer cover in intact.
- Cause :-** Improper assembly of hose end-fitting allow moisture to enter from the edge of outer socket. This moisture seeps up to 6 to 8 inches from end fitting. At edge due to heat generation moisture get pushed out deep inside, it remain trapped, cause corrosion and failure of hose.
- Remedies :-** End cover should be fitted in such a way, it should not allow moisture and chemical to enter between reinforcement and out-cover.
- viii. Problem :-** These are blisters in the outer cover of the hose. If one punctures blister, oil will come out.
- Cause :-** Faulty inner lining, or a inner lining which got damage while fitting reusable nipple in it, allows oil to enter in reinforcement, and bellow outer cover. And where adhesion of outer cover is weak it get accumulated in form of blister.
- Remedies :-** Lubricate inner nipple while assembling the end fitting and avoid all type of damage to inner liner.
- ix. Problem :-** The inner liner of the hose is badly deteriorated with evidence of extreme swelling.
- Cause:-** Material of inner liner is not compatible with fluid used.
- Remedies:-** Use hose which is compatible with fluid.

**x. Problem :-** Teflon hose assembly has collapsed internally and hose fail at low pressure.

**Cause :-** Teflon is not rubber like material. When it is not handled properly. The places, where it bends and collapses that point become very weak and fail at much less pressure.

**Remedies:-** Handle Teflon hose carefully, and do not allow it to collapse while bending.

### 6.16 Precaution Against Accident, While Working with Fluid Conductor: -

1. Highly Pressurized fluids escaping from a small pinhole can be almost invisible, but then also it can exert extreme force. It can penetrate skin and cause blood poisoning, or severe injury to tissues, It can result in loss of the injured body part or death. Hence never check leakage with bare hand; instead use a piece of paper, or cardboard etc., wear safety glasses.
2. Hot fluid can cause severe burn. Pressurized fluid if released uncontrolled, can exert a tremendous explosive force. Hence avoid working with pressurized fluid lines, and if you have to work, then keep a shield between you and fluid-line, and take all possible precaution.
3. Hydraulic fluids are flammable. Take necessary precaution your-self, while working etc. and design fluid-line in such a way that if they passes near source of heat, an accidental leakage do not cause a fire.
4. Except few thermoplastic hoses all hoses are electrical conductors. Take precaution, while using hoses in electrical power lines.

### 6.17 Design and Commissioning of Fluid Conductor :-

1. Decide which type of fluid conductor you want to use. Prefer pipe or tube for those pipe line, which are permanent and fix type, whose replacement and maintenance is too difficult. Use hoses for those pipe line in which two unit between whom hoses are connected may change mutual distance or in those cases in which pipe line must flex or bend. Remember hoses have some limited life, and it requires maintenance and replacement after certain period of operation.
2. If you decide steel pipe line then decide which type of pipe you want to use. If you have well trained fitters who can bend tube without heating using rollers and dies then use tubes. And if systematic bending by rollers and dies are not possible and tubes have to be heated then use pipes of 80 to 160 schedule. Which have thick wall thickness, hence do not kink or collapse while heating and bending.
3. If pressure is upto 3000 PSI use ferrule type compression fitting. If pressure is high or vibration and miss-use may happen then use weldable type end-fitting. For weldable type end-fitting pipes of thick wall thickness are more preferable.
4. While designing the route always remember that all the joint and end-fitting has to be frequently checked and tighten, hence they should always be accessible, and easy to tighten.
5. We have described the type of load coming on pipes and end-fitting in “blow-off-feature”. Hence always consider sufficient fixing and holding point in pipe line so that even if end-fitting blow-off, it does not hit any one. Decide and insist for colour code for high pressure, exhaust, suction and drain pipe lines etc.
6. As inside diameter of hoses and tubes are difficult to check. Hence take more precaution to ensure that it is free from all type of foreign particle and dust.
7. Steel pipes generally rusted from both inside and outside. Outside could be easily derusted and painted, but it is very difficult to clean from inside. Before bending pipe see and check visibly for any large piece of cloth, stone or any thing stacked in pipe. Then after heating, bending and welding etc. pass compressed air to remove the scaling. Then use acid to completely clean the rust and dirt from inside.

After cleaning from acid, immediately apply oil, as acid or water residue immediately again corrode the pipe.

8. Always keep both end-closed for ready to assemble pipes.
9. Standard roller assembly are available in market for bending of pipe use it for bending. Try to design and lay the pipe line systematically, as once piping completed and machine dispatched it is very difficult to do any changes on site.

**Standard Carbon Steel Seamless Pipe available as per ASTM Standard:**

NOMINAL SIZE	OUTSIDE DIAMETER		WALL THICKNESS		CLASS	SCHE-DULE	PLAIN END								
							NOMINAL WEIGHT			TEST PRESSURE MIN.					
										BUTTWELDED		GRADE A		GRADE B	
IN.	MM	IN.	MM.	-	-	LB/FT	KG/FT	KG/M	PSI	KG/CM <sup>2</sup>	PSI	KG/CM <sup>2</sup>	PSI	KG/CM <sup>2</sup>	
1/8	.405	10.3	.063	1.7	std	40	.24	.11	.36	700	49.2	700	49.2	700	49.2
			.095	2.4	xs	80	.31	.14	.46	850	59.8	850	59.8	850	59.2
1/4	.540	13.7	.088	2.2	std	40	.42	.19	.63	700	49.2	700	49.2	700	49.2
			.119	3.0	xs	80	.54	.24	.80	850	59.8	850	59.8	850	59.8
3/8	.675	17.1	.091	2.3	std	40	.57	.26	.85	700	49.2	700	49.2	700	49.2
			.126	3.2	xs	80	.74	.34	1.10	850	59.8	850	59.8	850	59.8
1/2	.840	21.3	.109	2.8	std	40	.85	.39	1.26	700	49.2	700	49.2	700	49.2
			.147	3.7	xs	80	1.09	.49	1.62	850	59.8	850	59.8	850	59.8
3/4	1.050	26.7	.133	2.9	std	40	1.13	.51	1.68	700	49.2	700	49.2	700	49.2
			.154	3.9	xs	80	1.47	.67	2.19	850	59.8	850	59.8	850	59.8
1	1.315	33.4	.154	3.9	std	40	1.47	.67	2.19	850	59.8	850	59.8	850	59.8
			.308	7.8	xxs	160	2.44	1.11	3.63	1000	70.3	1000	70.3	1000	70.3
1 1/4	1.660	42.2	.133	3.4	std	40	1.68	.76	2.50	700	49.2	700	49.2	700	49.2
			.179	4.5	xs	80	2.17	.98	3.23	850	59.8	850	59.8	850	59.8
1 1/2	1.900	48.3	.358	9.1	xxs	160	3.66	1.66	5.45	1000	70.3	1000	70.3	1000	70.3
			.140	3.6	std	40	2.27	1.03	3.38	1000	70.3	1000	70.3	1000	77.3
1 3/4	2.375	60.3	.191	4.9	xs	80	3.00	1.36	4.46	1300	91.4	1500	105.5	1600	112.5
			.382	9.7	xxs	160	5.21	2.36	7.75	1400	98.4	1800	126.6	1900	133.6
2	2.375	60.3	.200	5.1	std	40	2.72	1.23	4.05	1000	70.3	1000	70.3	1000	70.3
			.400	10.2	xxs	160	6.41	2.91	9.54	1400	98.4	1800	126.6	1900	133.6
2 1/2	2.875	73.0	.154	3.9	std	40	3.65	1.66	5.43	1000	70.3	2300	161.7	2500	175.8
			.218	5.5	xs	80	5.05	2.28	7.47	1300	91.4	2500	175.8	2500	175.8
3	3.500	88.9	.344	8.7	...	160	7.46	3.38	11.10	...	...	2500	175.8	2500	175.8
			.436	11.1	xxs	...	9.03	4.10	13.44	1400	98.4	2500	175.8	2500	175.8
3 1/2	4.000	101.6	.203	5.2	std	40	5.79	2.63	8.62	1000	70.3	2500	175.8	2500	175.8
			.276	7.0	xs	80	7.66	3.47	11.40	1300	91.4	2500	175.8	2500	175.8
4	4.500	114.3	.375	9.5	...	160	10.01	4.54	14.90	1400	98.4	2500	155.8	2500	175.8
			.552	14.0	xxs	...	13.70	6.21	20.39	1400	98.4	2500	175.8	2500	175.8
5	5.563	141.3	.18	4.8	...	...	6.63	3.01	9.87	1000	70.3	...	...	...	...
			.216	5.5	std	40	7.58	3.44	11.28	1000	70.3	2200	154.7	2500	175.8
6	6.625	168.3	.300	7.6	xs	80	10.25	4.65	15.25	1300	91.4	2500	175.8	2500	175.8
			.438	11.1	...	160	14.31	6.49	21.30	...	...	2500	175.8	2500	175.8
7	7.875	200.0	.600	15.2	xxs	...	18.58	8.43	27.65	...	...	2500	175.8	2500	175.8
			.188	4.8	...	...	7.63	3.46	11.35	1200	84.4	...	...	...	...
8	8.625	219.1	.226	5.7	std	40	9.11	4.13	13.56	1200	84.4	2000	140.6	2400	168.7
			.318	8.1	xs	80	12.51	5.67	18.62	1700	119.5	2800	196.9	2800	196.9
9	9.500	241.3	.156	4.0	...	...	7.25	3.29	10.79	1000	70.3	...	...	...	...
			.188	4.8	...	...	8.64	3.92	12.86	1200	84.4	...	...	...	...
10	10.500	266.7	.219	5.6	...	...	10.00	4.54	14.88	1200	84.4	...	...	...	...
			.327	8.3	std	40	10.79	4.89	16.06	1200	84.4	1900	133.6	2200	154.7
11	11.500	292.1	.237	6.0	xs	80	14.98	6.79	22.29	1700	119.5	2700	189.8	2800	196.9
			.438	11.1	...	120	18.98	8.61	28.25	...	...	2800	196.9	2800	196.9
12	12.500	317.5	.531	13.5	...	160	22.52	10.21	33.51	...	...	2800	196.9	2800	196.9
			.674	17.1	xxs	...	27.54	12.49	40.98	...	...	2800	196.9	2800	196.9
13	13.500	342.9	.258	6.6	std	40	14.62	6.63	21.76	...	...	1700	119.5	1900	133.6
			.375	9.5	xs	80	20.78	9.43	30.92	...	...	2400	168.7	2800	196.9
14	14.500	368.3	.500	12.7	...	120	27.04	12.27	40.24	...	...	2800	196.9	2800	196.9
			.625	15.9	...	160	32.96	14.95	49.05	...	...	2800	196.9	2800	196.9
15	15.500	393.7	.750	19.0	xxs	...	38.55	17.49	57.37	...	...	2800	196.9	2800	196.9
			.280	7.1	std	40	18.97	8.60	28.23	...	...	1500	105.5	1800	126.6
16	16.500	419.1	.432	11.0	xs	80	28.57	12.96	42.52	...	...	2300	161.7	2700	189.8
			.562	14.3	...	120	36.42	16.52	54.20	...	...	2800	196.9	2800	196.9
17	17.500	444.5	.719	18.3	...	160	45.34	20.57	67.47	...	...	2800	196.9	2800	196.9
			.864	21.9	xxs	...	53.16	24.11	79.11	...	...	2800	196.9	2800	196.9
18	18.500	470.0	.250	6.4	...	20	22.36	10.14	33.28	...	...	1000	70.3	1200	84.4
			.277	7.0	...	30	24.70	11.20	36.76	...	...	1200	84.4	1300	91.4
19	19.500	495.5	.322	8.2	std	40	28.55	12.95	42.49	...	...	1300	91.4	1600	112.5
			.406	10.3	...	60	35.66	16.18	53.07	...	...	1700	119.5	2000	140.6
20	20.500	521.0	.500	12.7	xs	80	43.39	19.68	64.57	...	...	2100	147.7	2400	168.7
			.594	15.1	...	100	50.93	23.10	75.79	...	...	2500	175.8	2800	196.9
21	21.500	546.5	.719	18.3	...	120	60.69	27.53	90.32	...	...	2800	196.9	2800	196.9
			.812	20.6	...	140	67.79	30.75	100.88	...	...	2800	196.9	2800	196.9
22	22.500	572.0	.875	22.2	xxs	...	72.42	32.85	107.77	...	...	2800	196.9	2800	196.9
			.906	23.0	...	160	74.71	33.89	111.18	...	...	2800	196.9	2800	196.9

10	10.750	273.0	.250	6.4	...	20	28.04	12.72	41.73	....	....	850	59.8	1000	70.3			
			.279	7.1	...	...	31.20	14.15	46.43	....	....	950	66.8	1100	77.3			
			.307	7.8	...	30	34.24	15.53	50.95	....	....	1000	70.3	1200	84.4			
			.365	9.3	std	40	40.48	18.36	60.24	....	....	1200	84.4	1400	98.4			
			.500	12.7	xs	60	54.74	24.83	81.46	....	....	1700	119.5	2000	140.6			
			.594	15.1	...	80	64.40	29.21	95.84	....	....	2000	140.6	2300	161.7			
			.719	18.3	...	100	77.00	34.93	114.59	....	....	2400	168.7	2800	196.9			
			.844	21.4	...	120	89.27	40.49	132.85	....	....	2800	196.9	2800	196.9			
			1.000	25.4	xxs	140	104.13	47.23	154.96	....	....	2800	196.9	2800	196.9			
			1.125	28.6	...	160	115.65	52.46	172.11	....	....	2800	196.9	2800	196.9			
			1.2	12.750	323.8	.250	6.4	...	20	33.38	15.14	49.67	....	700	49.2	800	56.2	
			.330	8.4	...	30	43.77	19.85	15.14	....	....	950	66.8	1100	77.3			
			.375	9.5	std	...	49.56	22.48	73.75	....	....	1100	77.3	1200	84.4			
.406	10.3	...	40	53.56	24.29	79.71	....	....	1100	77.3	1300	91.4						
.500	12.7	xs	...	65.42	29.67	97.36	....	....	1400	98.4	1600	112.5						
.562	14.3	...	60	73.22	33.21	108.96	....	....	1600	112.5	1900	133.6						
.688	17.5	...	80	88.57	40.17	131.81	....	....	1900	133.6	2300	161.7						
.844	21.4	...	100	107.29	48.67	159.66	....	....	2400	168.7	2800	196.9						
1.004	25.4	xxs	120	125.49	56.92	186.75	....	....	2800	196.9	2800	196.9						
1.125	28.6	...	140	139.68	63.36	207.87	....	....	2800	196.9	2800	196.9						
1.312	33.3	...	160	160.33	72.72	238.60	....	....	2800	196.9	2800	196.9						
14	14.000	355.6	.250	6.4	...	10	36.71	16.65	54.63	....	....	650	45.7	750	52.7			
			.312	7.9	...	20	45.68	20.72	67.98	....	....	800	56.2	950	66.8			
			.375	9.5	std	30	54.57	24.75	81.21	....	....	950	66.8	1100	77.3			
			.438	11.1	...	40	63.37	28.74	94.30	....	....	1100	77.3	1300	91.4			
			.500	12.7	xs	...	72.09	32.70	107.28	....	....	1300	91.4	1300	105.5			
			.594	15.1	...	60	85.01	38.56	126.51	....	....	1500	105.5	1500	126.6			
			.750	19.0	...	80	106.13	48.14	157.94	....	....	1900	133.6	2800	161.7			
			.938	23.8	...	100	130.79	59.33	194.64	....	....	2400	168.7	2800	196.9			
			1.094	27.8	...	120	150.76	68.38	224.36	....	....	2800	196.9	2800	196.9			
			1.250	31.8	...	140	170.22	77.21	253.31	....	....	2800	196.9	2800	196.9			
			1.406	35.7	...	160	189.15	85.80	281.49	....	....	2800	196.9	2800	196.9			
			16	16.000	406.4	.250	6.4	...	10	42.05	19.07	62.58	....	....	550	38.7	650	45.7
						.312	7.9	...	20	52.36	23.75	77.92	....	....	700	49.2	800	56.2
.375	9.5	std				30	62.58	28.39	93.13	....	....	850	59.8	1000	70.3			
.500	12.7	xs				40	82.77	37.54	123.18	....	....	1100	77.3	1300	91.4			
.656	16.7	...				60	107.54	48.78	160.04	....	....	1500	105.5	1700	119.5			
.844	21.4	...				80	136.58	61.95	203.25	....	....	1900	133.6	2200	154.7			
1.031	26.2	...				100	164.86	74.78	245.34	....	....	2300	161.7	2700	189.8			
1.219	31.0	...				120	192.40	87.27	286.32	....	....	2700	189.8	2800	196.9			
1.438	36.5	...				140	223.57	101.41	332.71	....	....	2800	196.9	2800	196.9			
1.594	40.5	...				160	245.22	111.23	364.93	....	....	2800	196.9	2800	196.9			
18	18.000	457.2				.250	6.4	...	10	47.39	21.50	70.53	....	....	500	35.2	600	42.2
						.312	7.9	...	20	59.03	26.78	87.85	....	....	600	42.2	750	52.2
						.375	9.5	std	...	70.59	32.02	105.05	....	....	750	52.7	900	63.3
			.438	11.1	...	30	82.06	37.22	122.12	....	....	900	63.3	1000	70.3			
			.500	12.7	xs	...	93.45	42.39	139.07	....	....	1000	70.3	1200	84.4			
			.562	14.3	...	40	104.76	47.52	155.90	....	....	1100	77.3	1300	91.4			
			.750	19.0	...	60	138.17	62.67	205.62	....	....	1500	105.5	1800	126.6			
			.938	23.8	...	80	170.84	77.49	254.24	....	....	1900	133.6	2200	154.7			
			1.156	29.4	...	100	208.00	94.35	309.54	....	....	2300	161.7	2700	189.8			
			1.375	34.9	...	120	244.14	110.74	363.32	....	....	2800	196.9	2800	196.9			
			1.562	39.7	...	140	274.30	124.42	408.20	....	....	2800	196.9	2800	196.9			
			1.781	45.2	...	160	308.55	139.96	459.17	....	....	2800	196.9	2800	196.9			
			20	20.000	508.0	.250	6.4	...	10	52.73	23.92	78.47	....	....	450	31.6	500	35.2
.375	9.5	std				20	78.60	35.92	116.97	....	....	700	49.2	800	56.2			
.500	12.7	xs				30	104.60	47.23	154.96	....	....	900	63.3	1000	70.3			
.594	15.1	...				40	123.06	55.82	183.13	....	....	1000	77.3	1200	84.4			
.812	20.6	...				60	166.50	75.52	247.78	....	....	1500	105.5	1700	119.5			
1.031	26.5	...				80	208.92	94.76	310.91	....	....	1900	133.6	2200	154.7			
1.281	32.5	...				100	256.15	116.19	381.19	....	....	2300	161.7	2700	189.8			
1.500	38.1	...				120	286.37	134.43	441.05	....	....	2700	189.8	2800	196.9			
1.750	44.4	...				140	341.10	154.72	507.61	....	....	2800	196.9	2800	196.9			
1.989	50.0	...				160	379.14	171.98	564.22	....	....	2800	196.9	2800	196.9			
24	24.000	609.6				.250	6.4	...	10	63.41	28.76	94.36	....	....	400	28.1	450	31.6
						.375	9.5	std	20	94.62	42.92	140.81	....	....	550	38.7	650	45.7
						.500	12.7	xs	...	125.49	56.92	186.75	....	....	750	52.7	900	63.3
			.562	14.3	...	30	140.80	63.87	209.53	....	....	850	59.8	1000	70.3			
			.688	17.5	...	40	171.17	77.64	254.73	....	....	1000	70.3	1200	84.4			
			.938	23.8	...	...	230.92	104.74	343.45	....	....	....	....	....	....			
			.969	24.6	...	60	238.92	108.09	354.61	....	....	1500	105.5	1700	119.5			
			1.219	31.0	...	80	296.53	134.50	441.28	....	....	1800	126.5	2100	147.7			
			1.531	38.9	...	100	367.45	166.67	546.82	....	....	2300	161.7	2700	189.8			
			1.812	46.0	...	120	429.50	194.82	639.16	....	....	2700	189.8	2800	196.9			
			2.062	52.4	...	140	433.24	219.19	719.14	....	....	2800	196.9	2800	196.9			
			2.314	53.4	...	160	542.69	245.89	806.72	....	....	2800	196.9	2800	196.9			

**Standard Pipe available as per Indian Standard:-**

Nominal Bore in	Outside Diameter				Thickness		Plain End		
	in	Mm	In	Mm	In	Mm	lb/ft	kg/ft	kg/m
<b>LIGHT</b>									
*1/8	.396	10.1	.387	9.7	.072	1.8	.243	.110	.361
*1/4	.532	13.6	.518	13.2	.072	1.8	.347	.157	.517
*3/8	.671	17.1	.656	16.7	.072	1.8	.453	.205	.674
1/2	.841	21.4	.825	21.0	.080	2.0	.640	.290	.952
3/4	1.059	26.9	1.041	26.4	.092	2.35	.944	.428	1.41
1	1.328	33.8	1.309	33.2	.104	2.65	1.35	.612	2.01
1 ¼	1.670	42.5	1.650	41.9	.104	2.65	1.73	.785	2.58
1 ½	1.903	48.4	1.882	47.8	.116	2.9	2.19	.993	3.25
2	2.370	60.2	2.347	59.6	.116	2.9	2.76	1.25	4.11
2 ½	2.991	76.0	2.960	75.2	.128	3.25	3.90	1.77	5.80
3	3.491	88.7	3.460	78.9	.128	3.25	4.58	2.08	6.81
4	4.481	113.9	4.450	113.0	.144	3.65	6.64	3.01	9.89
<b>MEDIUM</b>									
*1/8	.411	10.4	.386	9.6	.080	2.0	.273	.124	.407
*1/4	.547	13.9	.522	13.3	.092	2.35	.437	.198	.650
*3/8	.658	17.4	.660	16.8	.092	2.35	.573	.260	.852
1/2	.856	21.7	.831	21.1	.104	2.65	.822	.373	1.22
3/4	1.072	27.2	1.047	26.6	.104	2.65	1.06	.481	1.58
1	1.346	34.2	1.316	33.4	.128	3.25	1.64	.744	2.44
1 ¼	1.687	42.9	1.657	42.1	.128	3.25	2.11	.957	3.14
1 ½	1.919	48.3	1.889	48.0	.128	3.25	2.43	1.10	3.61
2	2.394	60.8	2.354	59.8	.144	3.65	3.42	1.55	5.10
2 ½	3.014	76.6	2.969	75.4	.144	3.65	4.38	1.99	6.51
3	3.524	89.5	3.469	88.1	.160	4.05	5.69	2.58	8.47
4	4.524	114.9	4.459	113.3	.176	4.5	8.14	3.69	12.1
5	5.534	140.6	5.459	138.7	.192	4.85	10.9	4.94	16.2
6	6.539	166.1	6.459	164.1	.192	4.85	12.9	5.85	19.2
<b>HEAVY</b>									
*1/8	.411	10.4	.386	9.8	.104	2.65	.331	.150	.493
*1/4	.547	13.9	.522	13.3	.116	2.9	.517	.235	.769
*3/8	.685	17.4	.660	16.3	.116	2.9	.686	.311	1.02
1/2	.856	21.7	.831	21.1	.128	3.25	.977	.443	1.45
3/4	1.072	27.2	1.047	26.6	.128	3.25	1.27	.576	1.90
1	1.346	34.2	1.316	33.4	.160	4.05	2.00	.907	2.97
1 ¼	1.687	42.9	1.657	42.1	.160	4.05	2.58	1.17	3.84
1 ½	1.919	48.8	1.889	48.0	.160	4.05	2.98	1.35	4.43
2	2.394	60.8	2.354	59.8	.176	4.5	4.14	1.89	6.17
2 ½	3.014	76.6	2.969	75.4	.176	4.5	5.31	2.41	7.90
3	3.524	89.5	3.469	88.1	.192	4.85	6.76	3.07	10.1
4	4.524	114.9	4.459	113.3	.212	5.4	9.71	4.40	14.4
5	5.534	140.6	5.459	138.7	.212	5.4	12.0	5.44	17.8
6	6.539	166.1	6.459	154.1	.212	5.4	14.3	6.49	21.2

**Carbon Steel Bright Annealed Seamless Tubes as per DIN-2391**

Outside Dai (Mm)	Wall Thickness (Mm)	Outside Dai (Mm)	Wall Thickness (Mm)	Outside Dai (Mm)	Wall Thickness (Mm)
3.55	0.55	12.00	1.50	19.00	3.50
6.00	1.00	12.00	2.00	20.00	2.00
6.00	1.50	15.00	1.00	20.00	2.50
6.00	2.00	15.00	1.50	20.00	3.00
6.00	2.25	15.00	2.00	20.00	3.50
8.00	1.00	16.00	1.00	22.00	2.00
8.00	1.50	16.00	1.50	22.00	3.00
8.00	2.00	16.00	2.00	22.00	3.50
10.00	1.00	18.00	1.50	25.00	2.00
10.00	1.50	18.00	2.00	25.00	2.50
10.00	2.00	19.00	2.00	25.00	3.00
12.00	1.00	19.00	3.00	25.00	3.50

## Chapter - 7

### HYDRAULIC SEALS

Hydraulic seal is a component, which prevents leakage between two mating parts. When seals are used to stop leakage between two moving parts it is called **Dynamic Seal**. When seals are used to stop leakage between two relatively stationary parts it is called **static seals**. Example of dynamic seals is, U-seal, O-ring, Chevron Packing, Compact seal and Composite seal etc. Examples of static seals are Gasket, Asbestos Packing, O-ring etc. A dynamic seal could be satisfactorily used in place of static seal, while a static seal may not give satisfactory performance when used in place of dynamic seal.

#### 7.1 Mechanics of Sealing: -

There are two principles of sealing.

- 1) Compression sealing.
- 2) Pressure energies sealing.

##### 7.1.1 Compression sealing: -

Following figure explains the principle of compression sealing. In this type of sealing, seals gets it's sealing properly when it is compressed against two mating parts. The compression should produce pressure on mating parts more then the fluid pressure, which this seal is suppose to confine. As the sealing material used in this type of sealing is in form of packing hence these types of seals usually called, **packing or Gland-packing**.

The compression seal (packing) demands the use of a material and section, which is readily compressed. Shape rigidly must be low, which will normally follow from easy compressibility. So that the face of the seal can be conform intimately to the shape or state of the surface against which it is pressed. To produce a seal it is necessary to apply compression on seal, so that the specific pressure  $P_c$  got developed due to compression is more than the fluid pressure,  $P_f$  which this seal is suppose to confine.

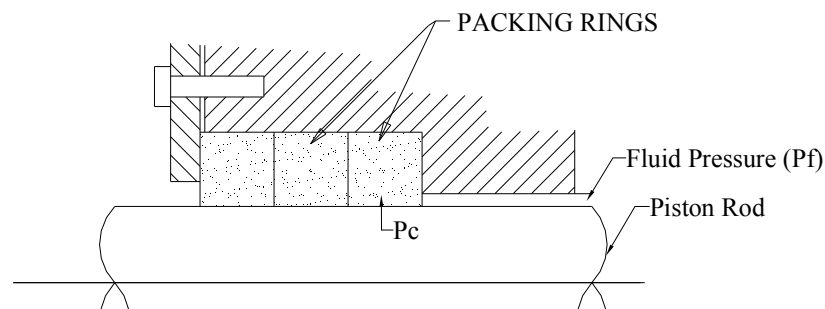

Figure No.7.1 Compression Sealing

As long as  $P_c$  is more than  $P_f$  sealing will be satisfactory, only precaution necessary is to ensure that the internal fluid pressure is not so high or the clearance gap so large that compressible material forming the seal is extruded through the clearance gap.

##### 7.1.2 Pressure-Energies Sealing: -

In this type of sealing, seal is made from flexible elastomer material. Seal develops its sealing property on receiving pressure from fluid, which it is supposed to seal.

On receiving pressure the seal deforms or expand and press firmly on the two mating parts and gives a fluid tight joint.

Nowadays compression type of sealing is outdated only pressure energies types of seals are used.

Pressure energies type of seals also could be divided in to two categories.

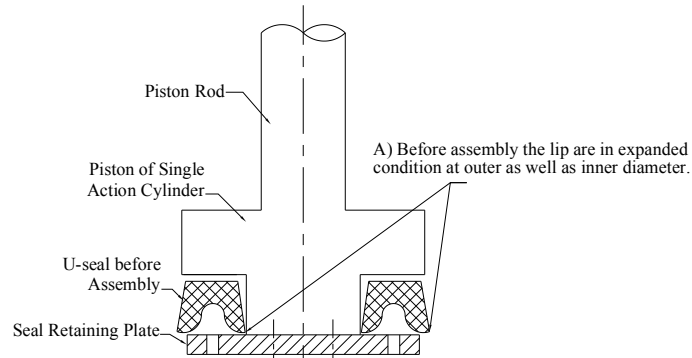

Figure No. 7.2

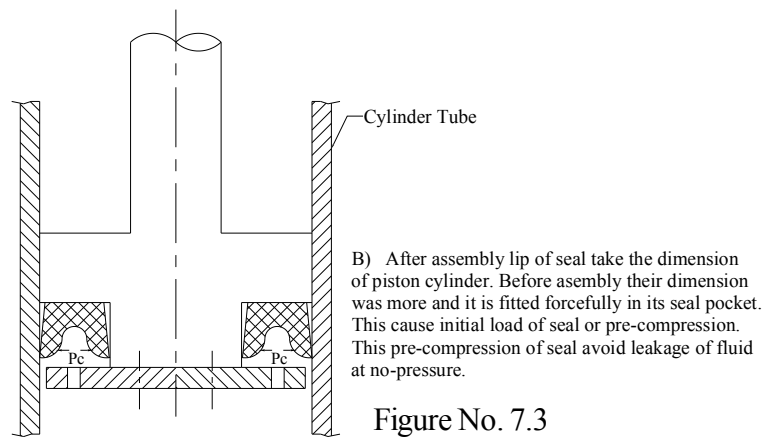

Figure No. 7.3

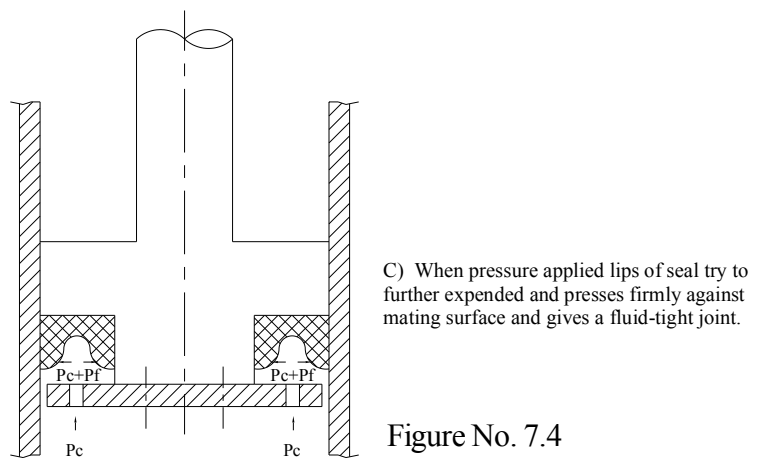

Figure No. 7.4



- i) Flexible lip type of seals.
- ii) Solid section type of seals.

U-seal and Chevron packing etc. are flexible lip type of seals. O-ring and composite seals etc. are solid section type of seals.

Lips of flexible lip type seals expand on receiving pressure, and press firmly on the two mating parts and give a fluid tight joint.

While in case of solid section type of seals, under fluid pressure seal deform and tries to extrude out from the clearance between two mating parts, and this wedging action gives a fluid tight joint.

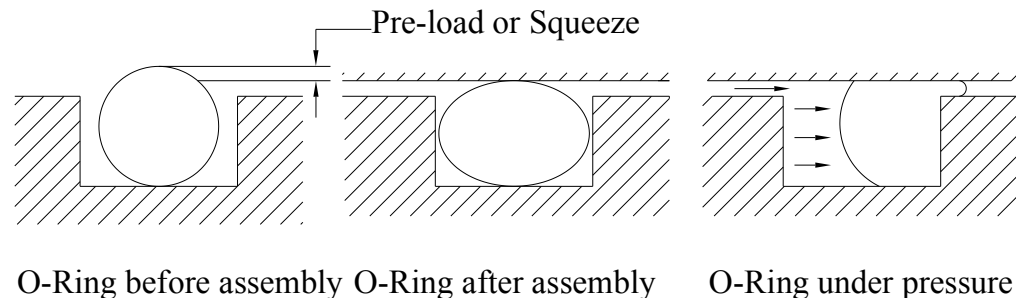

Figure No. 7.5

## 7.2 Factor affecting the Performance of Seals: -

Factor affecting performances of seals are.

- (1) Lubrication.
- (2) Toleration between mating part.
- (3) Friction, which depends upon pressure, time, speed, hardness of seal material and Number of seal used.
- (4) Compatibility of seal material with fluid.
- (5) Working condition (Temperature)

### 7.2.1 Lubrication: -

Lubrication of the seal face plays an important part in determining seal performance and seal life. Seal face, which rubs against moving parts, must be lubricated. Lubrication reduces friction. In absence of lubrication, higher friction will lead to local heating, which leads to deteriorated of seal material as well as residual oil, which produces abrasive product which further contribute to friction resulting in early failure of seal.

For better performance seals must be lubricated. In “Wet” application, hydraulic fluid provides the lubrication. For sealing gases or aqueous solution or steam, where fluid itself is not a lubricant, it is necessary to provide the seal face with a source of lubricant or impregnate the seal material with a lubricant.

When flexible seal used for sealing hydraulic oil, there is always oil - film on the rod surface on dry side of seal (out-side cylinder). This is normal and sign of good sealing. This oil film provides lubrication to seal. This film may attract dust particle from atmosphere, hence to avoid dirt entering in cylinder wiper seals are used. Wiper seal perform two function, it prevents entry of dust entering in cylinder, and upto certain extent it wipes excess oil, and some oil it pump - backs in cylinder,

This pump - back properly of wiper seal is very important and will be referred in advance seal design.

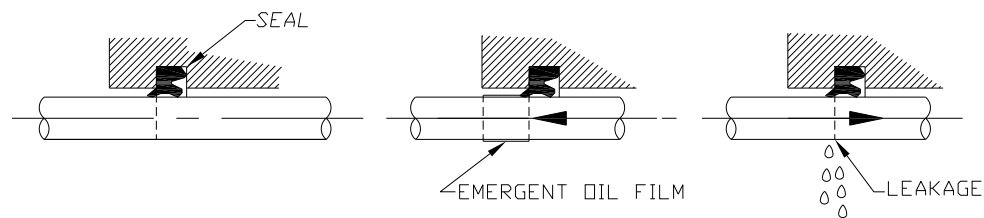

Figure No. 7.6

### 7.2.2 Clearance or Tolerance between Mating Parts: -

Frictional resistance in case of correct fitting of seal and correct clearance are calculated as follow.

$$\text{Friction} = (P_c + P_f) a \times \pi D$$

$\mu$  = Coefficient of friction,

$P_c$  = Pre-Compression

$P_f$  = Fluid-Pressure

$a$  = Width of Seal

$D$  = Inside diameter of seal.

But keeping all the parameter same, if wedging occur due to large clearance then formula gets modified to

$$\text{Friction} = \mu (P_c + P_f)^2 a \times \pi D,$$

From these two formulas you can understand how frictional resistance increases with wedging of seal.

Hydraulic cylinders are manufactured within very close Tolerance standard. If cylinders are made as per tolerance standard then the clearance remains well with in wedging limit. And in general clearance should be with in 0.05 to 0.125 mm. If clearance increases to 0.25 or more than, there is always chance of wedging action.

Wedging results in high friction, which increases wear and early failure of seal.

### 7.2.3 Seal Groove Dimension and Fitting: -

Now a days mostly pressure - energies seals are used in hydraulic cylinders. Dimensions of seal pocket or groove are very important in such seal. After fitting seals in groove, only flexible lips of seal should get compressed slightly in radial direction. Bottom of seal should not be squeezed. Under fluid pressure, flexible seal lips should be free to expand. There should not be axial compressive load, which hinders the expansion freedom of lips.

If bottom of seal get squeezed in seal pocket, it will result in high friction. If lips deform by over tightening of Gland-seal, then it will lead to leakage, excessive heating and seal wear as it affects on the pressure energizing process.

If seal pocket is of large size then lips of seal may not get the pre-compression load, and may leak-out at atmospheric pressure. And on pressure energisation may over-expand and tear-out.

For optimum life of a seal. Size of seal pocket and surface finish should be correct.

#### 7.2.4 Friction: -

Apart from representing power loss and wear friction at the seal surface interface result in heating which can cause degradation of both seal material and the hydro dynamic fluid film. Heating of fluid film yields abrasive products, which further contributing of friction and wear.

We have already discussed that lack of lubrication and wedging action leads to high friction. Other

Factors contributing to high friction are.

- (a) Surface Finish.
- (b) Hardness of Seal Material.
- (c) Working Pressure.
- (d) Rubbing Speed.
- (e) Standing Time.
- (f) Number of seal.

##### (a) Surface Finish: -

All elastomers are subjected to high rates of abrasion and wear in rubbing contact with relatively rough surfaces. As a general rule, on surface finish better than  $0.1 \mu\text{m Ra}$  on rubbing surface is essential for good seal life.

Extremely fine surface finish (less than  $0.020 \mu\text{m Ra}$ ) is also not desirable, it will not hold the surface - film of fluid for lubrication.

##### (b) Hardness of Seal Material: -

Generally seals are used with  $70^\circ$  shore hardness. But it may vary between  $40$  To  $95$  degree. Nowadays polyurethane seal of  $90^\circ$  hardness are widely used for better seal life.

Increase or decrease of friction will depend on the initial squeeze of seal. If initial squeeze of seal reduced then running friction will decrease with increase in hardness of material of seal. And if initial squeeze not decrease then increasing seal hardness will increase both breaks - out friction and running friction.

##### (c) Working Pressure: -

Flexible lip type of seal gets its sealing properly from fluid - pressure. Friction is proportional to working pressure and projected area hence any increase in pressure will correspondingly increase the frictional force.

Friction = Pressure x Projected Area

##### (d) Rubbing Speed: -

The relation between Coefficient of friction and rubbing speed can be explained with help of following figure.

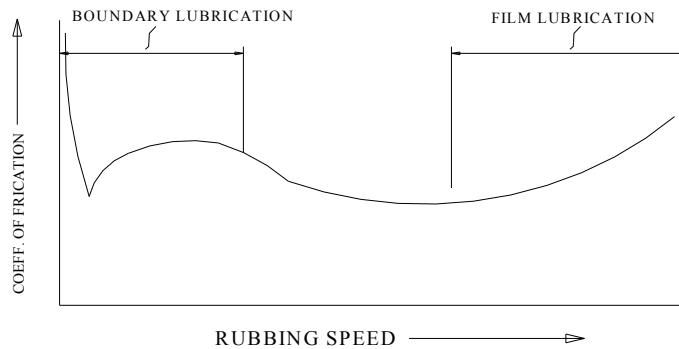

Figure No. 7.7

Static friction is high, but once ‘break - out’ has been initiated the frictional Coefficient fall to a low value at low speeds, but increases with increasing speed upto a first peak. From then on, with further increase in speed the frictional coefficient falls to a minimum value and then rises again with further increase in speed. This is a general presentation of the friction/speed relationship and can be modified by other conditions.

### (e) Standing Time: -

When seal stops rubbing and remains stationary, due to pre-compression force and flexibility of seal, seal material takes the shape of mating surface and fills the irregularity of the rough surface. This process is called ‘**Stiction**’ and this increases the coefficient of friction. Situation aggravates if the situation is favorable to the drying out of the lubricants on the seal face.

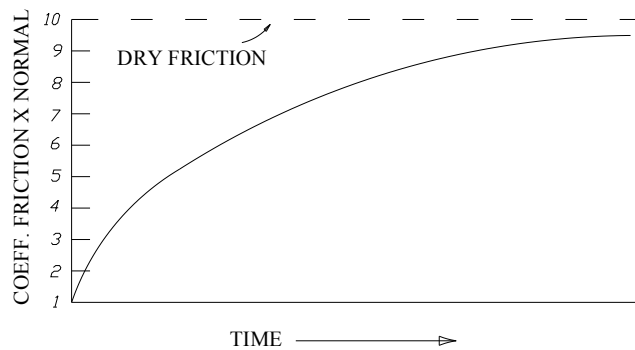

Figure No. 7.8

### Number of Seal: -

Where a number of identical seal rings are employed in a seal set, the total friction will obviously be greater than that of a single seal ring. But this increase in friction may not be directly proportional to the number of seal used, as all the seal do not faces the same pressure. First seal come in contact with fluid with stands full fluid pressure, while last will have more axial compression force than fluid pressure. Then also with increase in number of seals, friction increases.

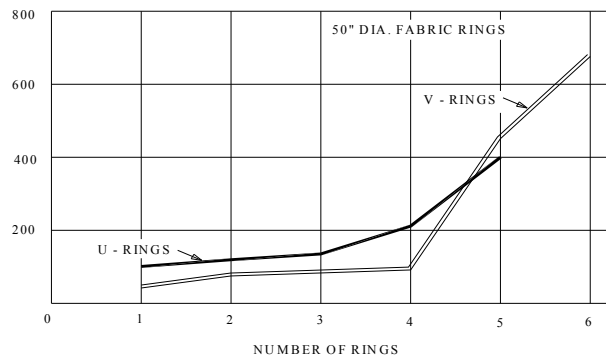

Figure No. 7.9

### 7.3 Compatibility of Seal Material with Hydraulic Fluid: -

There are three main categories of hydraulic fluid namely, mineral oil, synthetic fluid, and water - based emulsion and each category has so many grades of fluids depending upon application and condition. While seals are made from elastomer, plastomer leather and synthetic material.

All the seal material, are not compatible with all the hydraulic fluid. Some react adversely to some fluid, and become spongy, loses shape, strength, hardness and ultimately fails.

Hence to get desired performance from a seal only that hydraulic fluid should be used, which are compatible with seal material, (e.g. Natural rubber reacts with mineral oil and become spongy).

### 7.4 Temperature: -

Characteristic of seal material changes drastically with working temperature. It may become stiff, brittle at low temperature and break under pressure while loses hardness at high temperature and fails. Hence material of seal should be selected as per the expected working temperature of fluid to get best performance.

## SEAL MATERIALS

Depending on physical property sealing material could divide into two categories, **Elastomer & Plastomer**.

All rubber-like-material, we will describe them as elastomer. These materials are elastic, and capable of being stretched or extended by at least 100 percent, and ability to recover or reduce to within 10 percent of original length in a reasonable short time.

Plastomer are semi-rigid material such as PTFE etc.

These classifications are only for simplicity. They also include synthetic materials, and natural and mineral fibers, which exactly do not belong to any of these categories.

### 7.5 Elastomer: -

#### 7.5.1 Natural Rubbers: -

Natural rubbers are amongst the earliest of the true seal material. It is strongest and most wears resistant of all elastomer (only polyurethane is better than, natural rubber in this respect). It retains flexibly upto  $-55^{\circ}\text{C}$ . no other elastomer has this property except silicone, which is very costly.

Natural rubber has poor resistance to mineral oil hence it is not used nowadays. In earlier days, due to its excellent low temperature characteristics, it was used in castor - base fluid system (for example automobile hydraulic braking system, in limited extent aircraft hydraulic system etc.)

#### 7.5.2 Butyl: -

It is copolymer of isobutylene with isoprene. It is extremely resistant to water (better than chloroprene and nitrile) and other fluid. It is also very resistant to gas permeation making it attractive in seals for vacuum systems.

Butyl is also resistant to vegetable oil. In near past it was first choice seal material for use with phosphates ester type hydraulic fluid, although it is now replaced largely by ethylene propylene rubber. Butyl is not resistant to mineral base oils and aromatic solvents.

#### 7.5.3 Chloroprene: -

Chloroprene is generally known by its trade name 'Neoprene'. It is one of the general-purpose synthetic rubbers. It has excellent resistance to weather - aging. Its resistance to oil is moderate to good. It is generally used as rubber sheet as packing material and wiper seal, but not preferred for hydraulic seal.

#### 7.5.4 Chlorosulphonated Polyethylene: -

It is also known as CSM (Chlorosulphonated Monomer). This material is good resistant to acids, ozone and heat, and used in related application. Due to its low mechanical properties, it is not preferred for high - pressure sealing.

#### 7.5.5 Ethylene Propylene: -

Ethylene - propylene is also known as EP or EPM, have good - temperature characteristics and excellent resistant to many chemical solutions, such as organic solutions, solvent alkalize etc. It is also highly resistant to weathering ozone and aging. EP is not resistance to aromatic solvents, mineral oils, and petroleum products.

EP mainly used for hot water steam, phosphate ester, fire resistance fluids, silicone fluids etc.

Further copolymer of ethylene - propylene, which known as EPDM, has improved properties. It is used in form of V-cup seal, lip seal, chevron packing etc.

Physical properties after immersion in petroleum oil SAE-30 and distilled water.

Testing Medium	Test Condition		Tensile Strength		Elongation		Hardness		Change in Volume%
	Hrs.	°C	Kg/cm <sup>2</sup>	% change	%	% change	Points	change	
SAE-30 Oil	70	100	97.60	-36.4	112	.37.8	50 ±5	-30	+95.5
Distilled Water	70	100	155.25	+1.1	204	+13.3	79	-1	0

As per ASTM-2000 Ethylene Propylene should have following characters.

#### Mechanical Properties: -

1. Tensile Strength : 153.50 Kg/cm<sup>2</sup> (min)
2. Hardness Shore A : 80 ±5 (for O-ring)  
: 90 ±5 (for Seal)
3. Elongation : 180 min (for O-ring)
4. Modulus at 100% Elongation : 81.84 Kg/cm<sup>2</sup> (min)

#### 7.5.5.1 Fluoro Carbon: -

This is produced by copolymerisation of Vinylidene fluoride and hexafluoropylene and is most expensive in all sealing material.

Its outstanding properties are its high resistance to heat, chemicals, weathering and ozone. (It can be used upto maximum continuous temperature of 250°C) It resists material oils and grease containing sulphur, highly inflammable HFD fluids. It is not resistant to hydrous ammonia, caustic soda, caustic potash solution, ketons, ethers, dioxan, certain amines and organic acid.

It is used in form of U - cup seal, lip seal, chevron packing, wipers, various components and special seal.

It is widely known as viton (Registered trade name of Du. Pont).

### 7.5.5.2 Nitrile Rubbers: -

This is most important elastomer. It's use in industry is more than all other sealing material put together. Basically it is copolymer of Butadiene and acrylonitrile. Acrylonitrile content vary between 18 to 48 percent, and depending on its content it is designated as low medium or high nitrile.

Its resistance to petroleum base oil and hydrocarbon increases with increase of Acrylo Nitrile content, but at the same time low temperature - flexibility decreases with increasing nitrile content.

Nitrile rubbers have good physical characteristics, and are superior to most other rubbers as regards to cold flow, abrasion resistance and tear. They are susceptible to ozone. Weather and sun light, hence should not be stored near possible source of ozone e.g. near electric motor, sunlight etc.

Nitrile rubbers are particularly suitable for seals for petroleum - based fluids, water, silicone oils, grease, and glycol - base fire - resistance fluids. They are not suitable for use with halogenated hydrocarbon, nitrocarbons, phosphates ester fluid, ketones, strong acid, etc.

They are used in most of the forms, and shapes of seal, and could be used in homogenous form or in fiber impregnation for high strength.

### Mechanical Properties: -

1. Tensile Strength : 141 Kg/cm<sup>2</sup> (min)
2. Hardness Shore A : 70 ±5 (for O-ring)  
: 80 ±5 (for Seal)
3. Elongation : 250 min

Possible change in mechanical properties after heat aged in Air for 70 hours at 100°C.

1. Change in tensile Strength : -45%
2. Change in hardness : -20% points
3. Change in Elongation : -45%
4. Change in Volume : +60%

### 7.5.6 Polyacrylic (ACM): -

Polyacrylic rubber is produced by polymerization of acrylic acid esters. Its properties are midway between nitrile rubber and viton (Fluorocarbon rubber). One of the most attractive properties of this material is its excellent resistance to mineral oils and grease upto very high temperature. It has also excellent resistance to aging and flexes cracking, which makes it most suitable for rotary shaped seal application.

Low temperature characteristics are not good and mechanical strength and resistances to water are also inferior.

### 7.5.7 Polysulphide: -

This rubber has excellent resistance to fuel and solvents, oxygen, ozone, and aging. But it has poor mechanical properties and heat resistance. It also has very bad smell hence not used widely unless suitable alternative is not available.

### 7.5.8 Polyurethane: -

Thermoplastic polyurethane elastomer is recently developed elastomer with best mechanical properties as compared to nitrile and other sealing material. It has exceptional strength, tear and abrasion resistance (Better than all other rubber). Resistance is good to petroleum product, hydrocarbon, ozone, and weathering. But it is susceptible to aqueous solution of acid, or alkali, chlorinated hydrocarbon, ketones, hot water steam and glycol. It also loses its property at high and low temperature.

Nowadays various grades of polyurethane are also available, which are **hydrolysis - resistant** (hydrolysis is degradation in water) and which can give satisfactory performance upto 50 °C.

Polyurethane is moulded; it also could be machined on special machine in a form of U-cup seal, wiper seal, and chevron - packing from pre-molded pipes. This is very fast process and within few minutes you can get the seal of any odd size and shape.

### 7.5.9 Hydrogenated Acrylo Nitrile Butadiene Rubber: -

This material is suitable for application involving aliphatic hydrocarbons such as fuel, propane and butane, mineral oils, grease, vegetable and animal fat or oil. It also can be used in many diluted acids, alcohols, salt solution, and glycol water mixture upto 150 °C.

### 7.5.10 Silicon rubbers: -

This sealing material is an elastomer based on vinyl polysiloxane rubber. This material retains its mechanical performance over a wide range of temperature. It can be used as low as -70 °C. to maximum continuous service temperature upto 230 °C.

Silicon rubber has poor strength and tear and abrasion resistance, which can be improved by compounding. It has good resistance to alkalis weak acids and ozone, but moderate resistance to oil, which is again improved by compounding.

It is not recommended for use with hydrocarbon, such as petrol and paraffin, lighter mineral oil and steam etc.

One of its important applications is rotary seal. Where the operation temperature may be higher than that of permissible with conventional elastomer due to friction developed.

More recently developed Fluorosilicone rubber has good resistance to mineral oil. Hence it could be used for services where nitrile rubber cannot be used. Silicon rubbers are very costly.

## 7.6 Plastomer: -

Material in this range is generally Semi-rigid and mostly used for backing ring, anti-extrusion ring, guide ring, bush etc.

### 7.6.1 PTFE: -

It is polytetra fluoroethylene with unique properties. It is almost resistance to any chemical attack, outstanding service temperature range and coefficient of friction when rubbing on steel is of the same order as ice sliding on ice. Only molten alkali and gaseous fluorine at high temperature and pressure can attack it. It has poor mechanical properties, which are enhanced by reinforcement and filling.

PTFE cannot be stretched more than 10%. After stretching it recovers slowly and takes considerable time, hence back-up rings are made split or spiral type.



PTFE is mostly used as O-ring for sealing chemicals, backup ring, chevron packing, rotary seal and gasket.

When PTFE is reinforced with fillers it achieved high firmness and low creep as compared to pure PTFE. It is used for low friction seal thrust collars and bearing ring for chevron packing and guide rings.

Two similar plastomers to PTFE are PTFCE (poly trifluoro chloroethylene) and FEP (Flourinated ethylene propylene).

Main important features of these two materials are that they can be in action moulded to intricate shape. But their service temperature range is upto 200°C only and chemical resistance is not as good as pure PTFE.

PTFE is generally known by its trade name Teflon. Which M/s Dc-Pond has patented.

### **7.6.2 Polyoxyme Thylene Plastomer (POM): -**

This plastomer has very good mechanical property, good chemical resistance and low water absorption. It is used for anti-extrusion ring, guide rings, bushes, scrapers and other high precision rotating parts. It can be used with any mineral oil and grease, HFA, HFB, and HFC fluids. It is not resistance to concentrated acid and alkali solution.

### **7.6.3 Polyamide: -**

Polyamide has good sliding properties and used for guide ring and bearing components. It can be used with any mineral oil, grease HFA, HFB and HFC fluids. It absorbs water upto 8%.

**7.7** What ever we have described above is the basic material of sealing with their real technical name. However so may industries which are in business of manufacturing seals do R & D on these materials, and improved their properties by addicting various compound and modifying manufacturing processing. They give their own trade name to improved sealing material. Hide its actual technical name and keep the manufacturing process and additive added in it as their trade secret.

Hence you will find that a single material is called by different name by different seal manufacturer. For example “fluorine rubber” is called as VITON by DU PONT and it is their Register Trade Mark and ECONOMOS SEAL call same material as “ECORUBBER 2”.

Hence for any sealing requirement discuss your sealing requirement duty of operation, hydraulic fluid used and working temperature etc. with the engineers of seal supplier before selecting any type of seal and sealing material.

**7.7.1 Trade Name of Elastomer: -** In following chart we describe summery of elastomer material, their various trade name, their abbreviation by ISO-1629 and ASTM-1418.

Technical Name	Trade Name	Abbreviation		
		ISO 1629	ASTM 1418	B+S
Nitrile Elastomer Acrylonitrile-Butastomer Elastomer	Buna N <sup>®</sup> / Europrene N <sup>®</sup> / Nycar <sup>®</sup> / Nipol N <sup>®</sup> / Perbunan N <sup>®</sup>	NBR	NBR	N
Polyacrylate Elastomer	Europrene AR <sup>®</sup> / Nipol AR <sup>®</sup>	ACM	ACM	A
Tetrafluorethylene-Propylene Copolymer Elastomer	Aflas <sup>®</sup>	-		WT
Butyl Elastomer	Esso Butyl <sup>®</sup> / Polysar Butyle <sup>®</sup>	IIR	IIR	WI
Polychloroprene Elastomer	Baypren <sup>®</sup> / Neoprene <sup>®</sup>	CR	CR	WC
Polysulphide Elastomer	Thiokol <sup>®</sup>	-	TWT	WY
Chlorosulphonated Polyethylene	Hypalon <sup>®</sup>	CMS	CMS	WM
Ethylene-Propylene-diene Monomer Elastomer	Dutral/Keltan <sup>®</sup> / Vistalon <sup>®</sup>	EPDM	EPDM	E
Epichlorohydrin Elastomer	Herclor <sup>®</sup> /Hydrin	ECO	ECO	WO
Fluoroelastomer	Fluorel <sup>®</sup> / Tecnoflon <sup>®</sup> / Viton <sup>®</sup>	FPM	FKM	V
Fluorosilicone Elastomer	Silastic <sup>®</sup>	MFQ	FVMQ	F
Natural Rubber	Natsyn <sup>®</sup>	NR	LNR	WR
Polyester Urethane Elastomer Polyether Urethane Elastomer	Adiprene <sup>®</sup> /Urepan <sup>®</sup> /Vulcollan <sup>®</sup> Desmopan <sup>®</sup>	AU EU	AU EU	WU WU
Silicone Elastomer	Rhodorsil <sup>®</sup> / Silastic <sup>®</sup> / Silopren <sup>®</sup>	MVQ	VMQ	S
Styrene-Butadiene Elastomer	Buna S <sup>®</sup> / Uuroprene <sup>®</sup> / Polysar S <sup>®</sup>	SBR	SBR	WB
Perfluorinated Elastomer	Kalrez <sup>®</sup> / Zalak <sup>®</sup>	-	FFKPM	D
Hydrogenated Acrylonitrile- Butadiene Elastomer	Therban <sup>®</sup> / Tornac <sup>®</sup> / Zetpol <sup>®</sup>	HNBR	HNBR	H

These Trade name are Messers BASF, Good rich, Nippon Zeon, Bayer AG, DuPont Dow Elastomers, Esso Chemie, Wacker Chamie, Montediosn, Polysar Ltd. 3 M Company.

## 7.7 U-SEAL

In this category u-seal is most widely used in industries. It is called “U-Seal” or “U-Cup” seal, because of the shape or cavity between two lips is of U-shaped. For low Pressure application. U-seal is moulded using nitrile rubber without any reinforcement. Such seal can work upto 70 Bar but for application upto 200 bar reinforcement is necessary. For reinforcement, cloths with thick fiber are impregnated with rubber using chemical. Then they are pressed in mould under pressure and heat. Under pressure and heat rubber gets vulcanised and gives good strength seal.

Now polyurathene (PU) is discovered which has much better strength and characteristic then nitrile rubber. Seals moulded in PU can withstand upto 400 Bar pressure.

Nowadays seal-manufacturing process is also improved. Moulding requires long time because first making mould, then heating and pressing of material for Moulding. Size of mould also once made, cannot be changed. In new technique PU pipes of various sizes are first extruded and stored. Then whatever size of seal is required is machined from such pipe on CNC turning machine. PU with 90-degree hardness could be easily machined. And any odd size could be produced.

This process does not require mould making and storing such bulky moulds. It does not require long processing Moulding time. A seal could be machined with in 2 to 3 minute’s time. This process also removes restriction on selecting standard size. As any odd size could be machined any time. Hence this type of manufacturing is gaining more and more popularity.

### **7.8 Design and Dimension of U-seal: -**

Following facts must be clearly understood while selecting and a u-seal

**7.8.1** Seal is made from elastic material and will deform under pressure. Hardness and material strength of seal should be as per working pressure and temperature. For low-pressure pure nitrile is used, for medium pressure fiber impregnated nitrile is used, for high pressure Polyurathene is used, for higher temperature silicone or viton are used. (We are referring moulded type fiber impregnate seal again and again for better under standing, as for last 50 year it is used. But nowadays, it has been replaced by more advanced material and seal).

**7.8.2** In hydraulic cylinder only one side of lip is rubbed against moving part and other remains stationary. Hence there will be wear and tear on only on one side. Hence one lip will more stronger than other one, to compensate wear. Bottom of one side will have more clearance from moving part to avoid excessive rubbing, and friction.

**7.8.3** Oil must have access to come at center of u-shape cavity of seal to expand both lips equally. One lip near moving part side will be slightly shorter than the other one, for free entry of oil at the center of seal.

**7.8.4** Piston rods have very smooth surface. Wiper seal try to wipeout all oil film from piston rod surface. Hence when piston rod travels in a dry surface may rub against seal, which may cause heat generation.

Hence U-seal provided at rod end has one more small lip like projection at it bottom side (solid side). This helps in wiping out excess oil when piston rod extended out, it stores oil between two lips. And when piston rod retracts it provide lubrication between seal and piston rod surface. This increases the seal life.

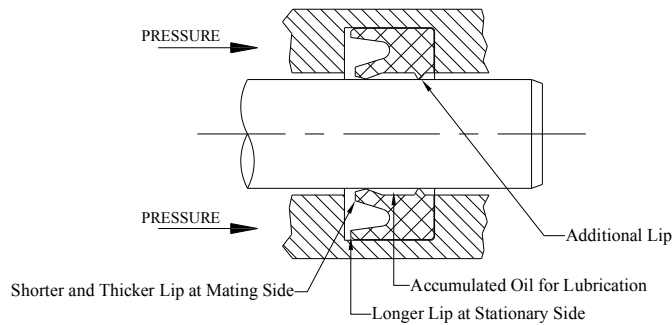

Figure No.7.10

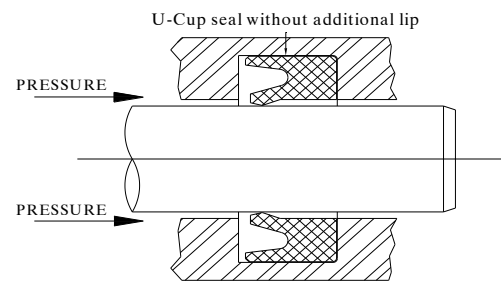

Figure No.7.11

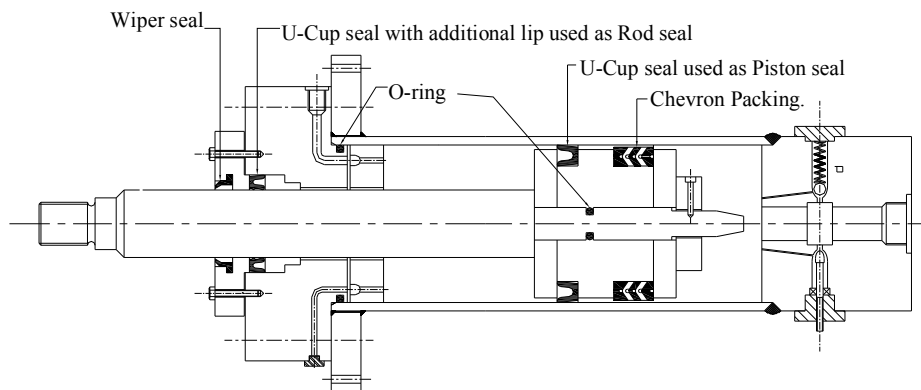

Figure No.7.12 Cross section of a Double Action Cylinder

### 7.9 U-seal for Corrosive Medium: -

Hydraulic seals are also used for fluid of corrosive nature. For such medium, seal material should be compatible with corrosive medium. One of the best material for corrosive fluid is PTFE. PTFE is compatible to all acid, alkali and other chemical. But PTFE is elastomer. A simple U-seal may not give satisfactory sealing at low pressure. Hence to develop the initial pre-compression, for zero leakage at low pressure and to reinforce the seal, strength is provided with metallic spring in form of V-ring as shown in following sketcher.

At low-pressure metal-spring provide pre-compression load to give zero leakage, while at high pressure seal get pressure energized and give satisfactory performance up to pressure of 450 Kg/Cm<sup>2</sup>.

As metallic V-ring is stiff hence such seal can not be fitted in groove. It require split type cavity for easy accommodation of seal. The PTFE U-seal lips are also given slight curves inside to hold V-ring in place as shown diagram. V-ring is made from stainless steel.

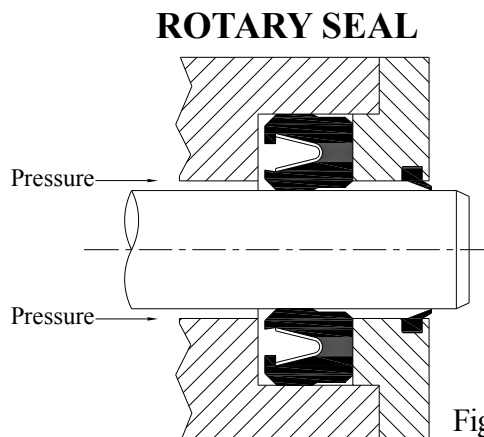

Figure No.7.13

## Rotary Seal

### 7.10 Rotary Seal: -

Hydraulic cylinders have linear motion, but there are also applications in which fluid is to be sealed in rotating mating parts. Such application may require, sealing of high-pressure fluid, medium pressure fluid or slow pressure fluid. Depending on working pressure and type of hydraulic medium following types of seals are used.

#### 7.10.1 V-Seal: -

For sealing of fluid, grease etc. at atmospheric pressure V-Seals are used. Such seals only retain lubricating material within its casing and avoid entry of dust and other contamination in bearing casing.

V-Seal has simple construction and principle of sealing. It is made from elastic material such as high nitrile rubber. Its construction consists of three main components. Main square ring, pivot, and flexible lip.

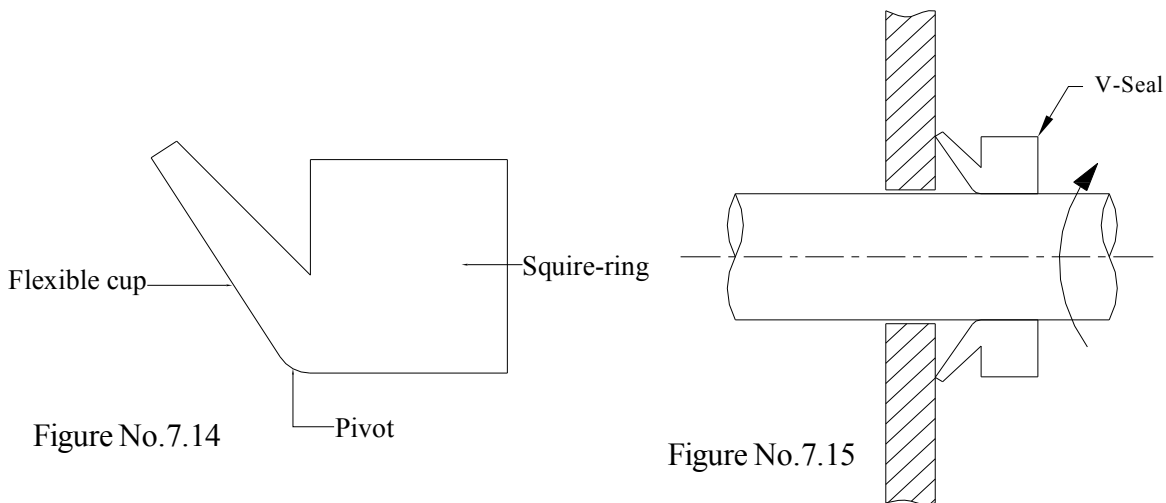

#### 7.10.2 Flanged U-Seal: -

For high pressure corrosive medium we do not have other alternation other than using U-seal made from PTFE, as we have discussed earlier. But one of the problem we face using U-seal of PTFE is that it start rotating along with start once it get pressure energies. To avoid this problem we make a flange at bottom of U-shape, and lock it as shown in following sketcher.

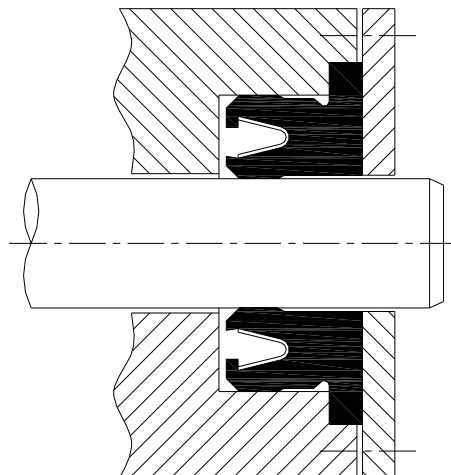

Figure No. 7.16

Roto Glyd Ring<sup>®</sup> of Bushak+ShambanQuad Ring<sup>®</sup> of Bushak+Shamban

Figure No.7.17

## CHEVRON PACKING

### 7.11 Chevron Packing: -

Before discovery of polyurathene a u-seal made from fiber impregnated nitrile rubber was not stronger enough to withstand pressure more than 200 Bar. Also once lips of u-seal wears out system start leaking. To over-come these two problems, chevron packing developed, which is widely used still in industry.

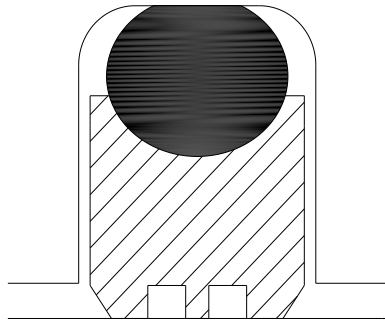
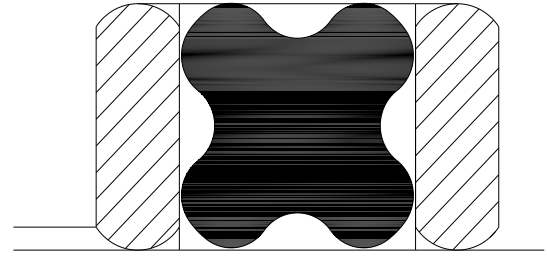
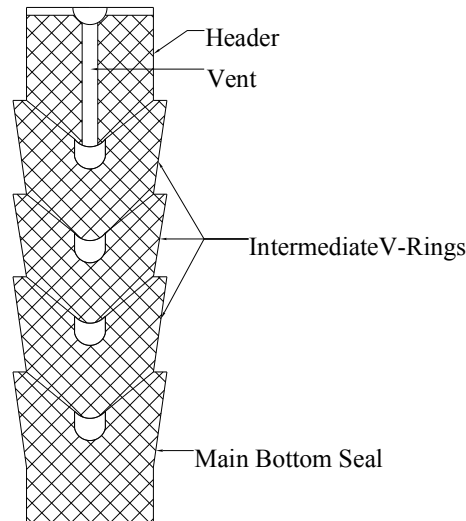

Figure No.7.18

It consists number of seal rings. Main seal is a V-shaped seal instead of u-shaped. In its V-groove number of seal rings are fitted which again have V-shaped cavity between its lips, also V-shape bottom portion which is to be accommodated in cavity of other V-seal and last seal is a solid section with flat surface on one side and V-on seal side. It is called header. Header has venting holes. Through which oil passes both side of seal as well as at center of 'V' to symmetric expansion of the seal.

Individual u-seal or v-seal is never compressed in its longitudinal direction but above-mentioned seal set could be compressed, like gland packing and because of this reason it is called seal packing or chevron packing.

Initial compression on packing avoids the leakage at atmospheric pressure. On receiving pressure, first seal come in contact of pressurized fluid; it expands and does the function of fluid sealing. At this time other seal only remain under compression. After remaining in service for sufficient time, when first v-seal wear out next seal start sealing the fluid. In this way seal works satisfactorily till last seal wears out.

Hence this type of seal has three advantages.

- i. Initial pre-compression always could be adjusted and wear compensated by increasing the longitudinal compression.
- ii. Life of seal is much more than single u-seal.
- iii. It can take higher pressure than single u-seal.

## 7.12 O-RING

O-ring is solid section pressure energies type of seal. O-ring seal is simplest form of seal, which if correctly selected and used, than can give satisfactory result upto 30,000 PSI in case of static application and 5000 PSI in case of dynamic application.

### Factor affects the Performance of an O-ring: -

Hence they must be carefully considered before using an O-ring as a seal.

#### 7.12.1 Compatibility: -

O-rings are made from elastomer. Many elastomers have poor resistance to number of hydraulic fluid used. If an elastomer react with fluid, it swells-out, looser, hardness, strength and ultimately fail in service. Hence only those elastomer could be used which are compatible with working fluid.

#### 7.12.2 Hardness Of Seal Material: -

A softer material about 60<sup>0</sup>PS hardness will provide better sealing at low pressure, while a harder material 90<sup>0</sup>, will give better stability at higher working pressure. Hardness range of O-ring material is from 60<sup>0</sup> to 90<sup>0</sup> and for general purpose, 70<sup>0</sup> -75<sup>0</sup> PS is used. Depending of working pressure and condition correct hardness should be used.

#### 7.12.3 Clearance: -

The sealing principle of an o-ring is shown diagrammatically in following figure. The initial squeeze provided the initial sealing pressure. On increase of pressure, o-ring shifts to one side of groove. It deform, try to extrude through the clearance and while doing so it provide positive sealing. O-ring provides sealing due to its tendency to extrude, but if the clearance is large enough then it actually get extruded and fails. Hence manufacture of o-ring provides data regarding groove dimension, clearance gap and hardness of seal material for various pressure applications, which must be observed for satisfactory performance of o-ring seal.

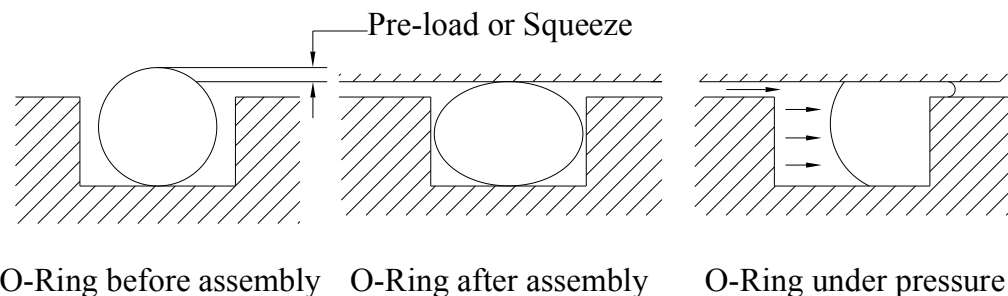

Figure No.7.19

Cylinder expands under pressure and with rise in temperature; hence this factor also must be considered while deciding clearance gap.

#### 7.12.4 Groove Dimension: -

The basic principle of sealing by o-ring is that there should be some initial squeeze on initial assembly in groove, it try to extrude and while doing so provide positive sealing. Hence this process involves.

- a) Initial squeeze.
- b) Movement in groove to one side of groove wall.



c) Tendency to extrude out.

For satisfactory performance of o-ring squeeze should be correct. If it is less then it will not give sealing at atmospheric pressure, and give leakage. And on pressurising also it may not slide to one side as fluids have free passage to pass over o-ring.

And if the squeeze is excessive, then it will result in excessive friction. In case of excessive friction if surface finish of mating surface is rough than o- ring will fail by wear. Frictional force also tries to twist the o- ring in groove. In case of reciprocating motion, part of o-ring slides and part of o- ring rolls along mating surface, in such case o- ring gets twisted and failed, this type of o- ring failure is called **spiral failure**. Generally inside surface of groove are not very smooth. O- ring slide one side of groove wall to other side as direction of pressure charges. If the groove width is large enough than o-ring rubber on large distance on bottom of groove and fail by wearing-out.

O- ring tends to extrude out under pressure. Hence under pressure it presses firmly on one edge of groove. If the edges have sharp edge that it acts as cutting edges, hence the slope, edges corner, and surface finish of groove must be perfect.

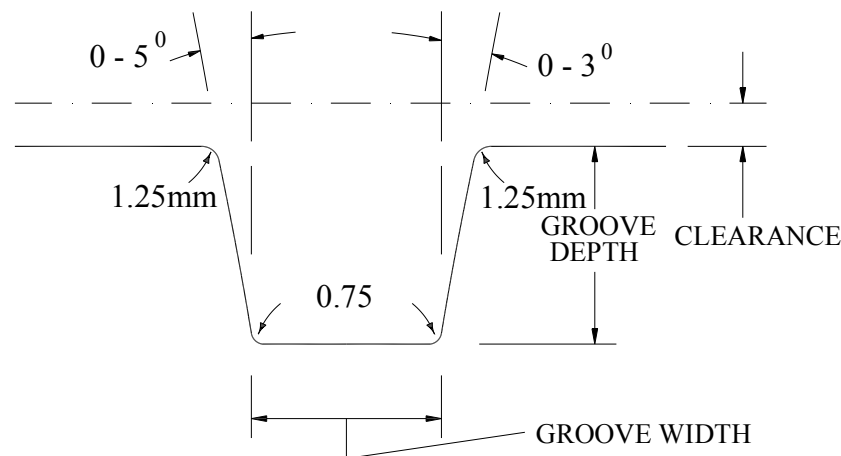

Figure No.7.20

### 7.12.5 Other Factors: -

Which increase the frictional, and affect the performance of seal are as follow.

a) **Speed of motion: -**

Slow speeds increase the frictional force.

b) **Cross-section of O-ring: -**

Large cross - section of seal offer more projected area, if rubbing is more, friction and wear is bound to be move.

c) **Lubrication: -**

Absence of lubrication results in excessive friction. Hence material like PTFE should be selected when lubrication is not possible. Otherwise external lubrication must be provided to reduce friction and wear.

d) **Temperature: -**

Elastomer looses its hardness and strength at high temperature and looses its elasticity at low temperture. Hence material of o-ring should be selected as per working temperature.

Nitrile could be safely used upto 70 C, polyurethane upto 100 C, PTFE upto 200 C, and silicate upto 300 C temperature.

### 7.13 Types of O-ring: -

#### 7.13.1 Rectangular Ring: -

It is rectangular in cross-section. It has advantage of more resistance against twisting and extrusion. And could be also produced by punching from elastomer sheet. Movement of rectangular rings is less in same size of groove as compared to o-ring, hence mechanical back-lash is less. Low mechanical backlash characteristic makes it more useful in small reciprocating cylinder. Disadvantage of this seal is that, it has more contact area with mating part, hence friction and wears are more as compared to o - ring.

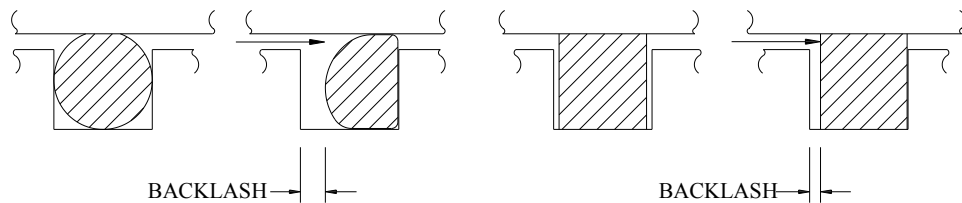

Figure No. 7.21

#### 7.13.2 Quad And H-Ring: -

These rings are further improvement of rectangular ring. They have depression on flat surface to reduce the large contact area to minimize friction. These rings have more resistance against twisting and spiral failure than o-ring, hence generally used in dynamic application. And for reciprocating action. Nu-Lip also has same configuration with slight shape difference.

Quad is a Trademark of Du Pont and made in standard size and interchangeable with standard o-ring.

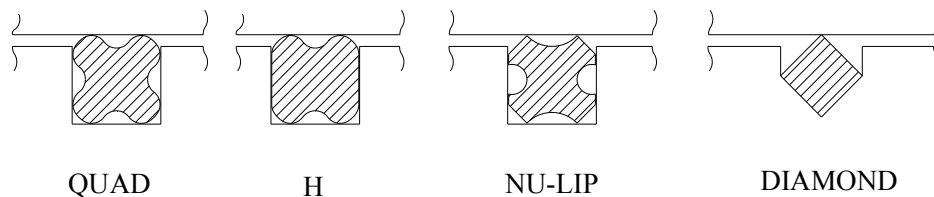

Figure No. 7.22

#### 7.13.3 Delta & Tee-ring: -

It has less friction, but more backlash, large base provided good stability against twisting and less contact area provides less friction resistance.

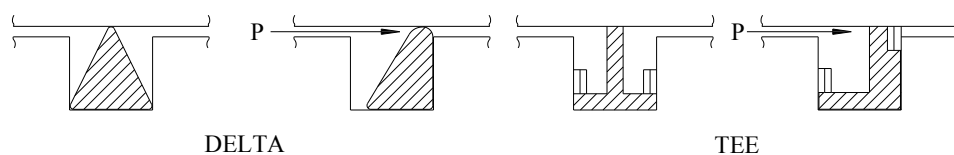

Figure No. 7.23

### 7.13.4 D-ring, Heart Ring Seal: -

These rings provide large base area, and more resistance against twisting. But do not have any distinct advantage over plain o - ring. Heart shape only finds its application in rotary sealing application.

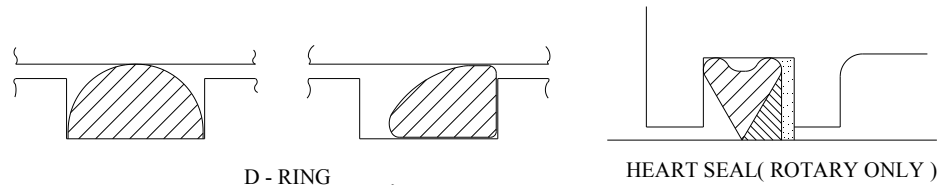

Figure No.7.24

O - ring could be used as seal for stationary, reciprocating, rotating mating parts, with internal pressure or vacuum. For same size of o - ring same material and same pressure, groove size differ for different applications.

Table No. 1, 2, & 3 will give a general idea regarding the groove dimension for above these applications. For detail kindly get data from o-ring manufacturer.

### 7.14 Back-up Rings: -

To avoid the extrusion of o-ring from clearance gap back-up rings are used. These are fitted in opposite side of pressure from where o-ring tries to extrude out. If pressures are applied from both sides, then on both side of o-ring back-up ring are used.

Basic requirement of back-up ring is it should have low coefficient of friction; it should not collapse and cold flow. Surface of back-up ring should not have cut or irregularly.

Back-up rings are made from plastomer such as PTFE. Back-up ring may be flat or contorted as per o-ring shape.

O-ring with concave back-up ring are superior to flat back-up ring as it give more support to o-ring, it has more cross-section area at extrusion place, and contact and rubbing of o-ring with mating surface is less as compare to flat back-up ring. This promotes better performance and long life.

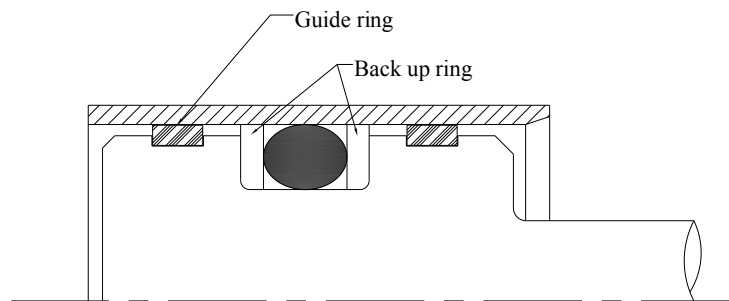

Figure No.7.25 Guide ring & Back-up ring

### 7.15 Guide-ring: -

Always some gap is kept between piston and cylinder to avoid metal-to-metal contact. But if due to side load, piston moves to one side then clearance on other side gets doubled and make a place for o-ring extrusion. Hence guide-ring is used. Guide-ring are fitted in such a way that they rub the mating surface take side load if any, and do not provide any side room for side

movement of piston and piston-rod. Guide-rings are elastomer with low coefficient of friction such as POM & polyamide, bronze filled PTFE etc. they are also called as wear rings.

### 7.16 Design Description about O-ring: -

1. O-ring are defined by the inside diameter ( $d$ ) and the cross-section ( $W$ ) (cord-diameter).

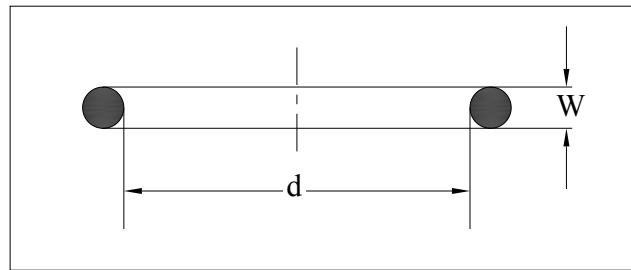

Figure No.8.26

2. Standard o-rings are available from app. 0.3mm to 12mm cross-section and upto 5000mm inside diameter.
3. O-rings are generally made from elastomeric material. In Chapter of seal material we have provided a summary of elastomer used for o-ring.
4. O-ring material is decided on basis of pressure, working temperature and working medium. For simple and general purpose hydraulic system, Nitrile elastomer is used with 70 shore A hardness.
5. In general o-ring without back-up ring can seal upto 200 Bar with back-up ring upto 400 Bar and with special elastomer and back-up ring upto 2000 Bar.
6. O-ring is squeezed in groove for initial sealing capability. O-ring is made from elastomeric material, which has elastic property, hence as soon as load of compression removed, it should return back to its initial shape and size. But in actual practice it also undergoes plastic deformation upto certain extent. Hence its cross-section remain oval even after removal of pre-compression, because of this reason the pre-compression should be sufficiently high to compensate the plastic deformation. It should be between 15 to 30% of cross-section area. And in no case it should be less than 6% in hydraulic and 2% in pneumatic application.
7. The o-ring manufacturers specify the groove depth and width. But in general groove depth is kept  $0.75 \times W$  and width  $1.36$  to  $1.4 \times W$ . where  $W$  is cross-section diameter of o-ring. When only o-ring is used sidewall could have a slop of  $5^\circ$ . But if back-up seals are used then straight walls are preferred. Bottom of groove should have surface finish  $1.5$  to  $2 \mu Ra$ . While the mating surface should have surfaced finish  $0.2$  to  $0.4 Ra$  value.
8. When o-ring is used over a groove on diameter of shaft, then inner diameter of o-ring is 1 to 3% small than the inner groove diameter of shaft, so that o-ring will always grip the bottom of groove, for pre-compression and positive sealing. And similarly when it is used in groove in a bore, then size of o-ring should be 1 to 3% more the outer groove diameter for same pre-compression and positive sealing purpose.
9. Above mention elongation or compression of o-ring should be within limit and must be taken into consideration, with designing groove size and selecting o-ring size, as every 1% elongation of o-ring size ( $d$ ) will reduce 0.5% cross-section diameter ( $W$ ).
10. ISO and DIN standard has standardized and specified various sizes of o-ring it helps in manufacturing and maintenance.

**A summary of O-Ring size as per ISO & DIN are as follows: -**

<b>Dimensions d × W</b>	<b>Dimensions d × W</b>	<b>Dimensions d × W</b>	<b>Dimensions d × W</b>	<b>Dimensions D × W</b>
1.80 x 1.80	25.00 x 2.65	58.00 x 5.30	122.00 x 3.55	258.00 x 5.30
2.00 x 1.80	25.00 x 3.55	60.00 x 3.55	122.00 x 5.30	258.00 x 7.00
2.24 x 1.80	25.80 x 2.65	60.00 x 5.30	125.00 x 3.55	265.00 x 5.30
2.50 x 1.80	25.80 x 3.55	61.50 x 3.55	125.00 x 5.30	265.00 x 7.00
2.80 x 1.80	28.00 x 2.65	61.50 x 5.30	128.00 x 3.55	272.00 x 5.30
3.15 x 1.80	28.00 x 3.55	63.00 x 3.55	128.00 x 5.30	272.00 x 7.00
3.55 x 1.80	30.00 x 2.65	63.00 x 5.30	132.00 x 3.55	280.00 x 5.30
4.00 x 1.80	30.00 x 3.55	65.00 x 3.55	132.00 x 5.30	280.00 x 7.00
4.50 x 1.80	31.50 x 2.65	65.00 x 5.30	136.00 x 3.55	290.00 x 5.30
4.87 x 1.80	31.50 x 3.55	67.00 x 3.55	136.00 x 5.30	290.00 x 7.00
5.00 x 1.80	32.50 x 2.65	67.00 x 5.30	140.00 x 3.55	300.00 x 5.30
5.15 x 1.80	32.50 x 3.55	69.00 x 3.55	140.00 x 5.30	300.00 x 7.00
5.30 x 1.80	33.50 x 2.65	69.00 x 5.30	145.00 x 3.55	307.00 x 5.30
5.60 x 1.80	33.50 x 3.55	71.00 x 3.55	145.00 x 5.30	307.00 x 7.00
6.00 x 1.80	34.50 x 2.65	71.00 x 5.30	150.00 x 3.55	315.00 x 5.30
6.30 x 1.80	34.50 x 3.55	73.00 x 3.55	150.00 x 5.30	315.00 x 7.00
6.70 x 1.80	35.50 x 2.65	73.00 x 5.30	155.00 x 3.55	325.00 x 5.30
6.90 x 1.80	35.50 x 3.55	75.00 x 3.55	155.00 x 5.30	325.00 x 7.00
7.10 x 1.80	36.50 x 2.65	75.00 x 5.30	160.00 x 3.55	335.00 x 5.30
7.50 x 1.80	36.50 x 3.55	77.50 x 3.55	160.00 x 5.30	335.00 x 7.00
8.00 x 1.80	37.50 x 2.65	77.50 x 5.30	165.00 x 3.55	345.00 x 5.30
8.50 x 1.80	37.50 x 3.55	80.00 x 3.55	165.00 x 5.30	345.00 x 7.00
8.76 x 1.80	38.70 x 2.65	80.00 x 5.30	170.00 x 3.55	355.00 x 5.30
9.00 x 1.80	38.70 x 3.55	82.50 x 3.55	170.00 x 5.30	355.00 x 7.00
9.50 x 1.80	40.00 x 3.55	82.50 x 5.30	175.00 x 3.55	365.00 x 5.30
10.00 x 1.80	40.00 x 5.30	85.00 x 3.55	175.00 x 5.30	365.00 x 7.00
10.60 x 1.80	41.20 x 3.55	85.00 x 5.30	180.00 x 3.55	375.00 x 5.30
11.20 x 1.80	41.20 x 5.30	87.50 x 3.55	180.00 x 5.30	375.00 x 7.00
11.80 x 1.80	42.20 x 3.55	87.50 x 5.30	185.00 x 3.55	387.00 x 5.30
12.50 x 1.80	42.50 x 5.30	90.00 x 3.55	185.00 x 5.30	387.00 x 7.00
13.20 x 1.80	43.70 x 3.55	90.00 x 5.30	190.00 x 3.55	400.00 x 5.30
14.00 x 1.80	43.70 x 5.30	92.50 x 3.55	190.00 x 5.30	400.00 x 7.00
14.00 x 2.65	45.00 x 3.55	92.50 x 5.30	195.00 x 3.55	412.00 x 7.00
15.00 x 1.80	45.00 x 5.30	95.00 x 3.55	195.00 x 5.30	425.00 x 7.00
15.00 x 2.65	46.20 x 3.55	95.00 x 5.30	200.00 x 3.55	437.00 x 7.00
16.00 x 1.80	46.20 x 5.30	97.50 x 3.55	200.00 x 5.30	450.00 x 7.00
16.00 x 2.65	47.50 x 3.55	97.50 x 5.30	206.00 x 5.30	462.00 x 7.00
17.00 x 1.80	47.50 x 5.30	100.00 x 3.55	206.00 x 7.00	475.00 x 7.00
17.00 x 2.65	48.70 x 3.55	100.00 x 5.30	212.00 x 5.30	487.00 x 7.00
18.00 x 2.65	48.70 x 5.30	103.00 x 3.55	212.00 x 7.00	500.00 x 7.00
18.00 x 3.55	50.00 x 3.55	103.00 x 5.30	218.00 x 5.30	515.00 x 7.00
19.00 x 2.65	50.00 x 5.30	106.00 x 3.55	218.00 x 7.00	530.00 x 7.00
19.00 x 3.55	51.50 x 3.55	106.00 x 5.30	224.00 x 5.30	545.00 x 7.00
20.00 x 2.65	51.50 x 5.30	109.00 x 3.55	224.00 x 7.00	560.00 x 7.00
20.00 x 3.55	53.00 x 3.55	109.00 x 5.30	230.00 x 5.30	580.00 x 7.00
21.20 x 2.65	53.00 x 5.30	112.00 x 3.55	230.00 x 7.00	580.00 x 7.00
21.20 x 3.55	54.50 x 3.55	112.00 x 5.30	236.00 x 5.30	600.00 x 7.00
22.40 x 2.65	54.50 x 5.30	115.00 x 3.55	236.00 x 7.00	615.00 x 7.00
22.40 x 3.55	56.00 x 3.55	115.00 x 5.30	243.00 x 5.30	630.00 x 7.00
23.60 x 2.65	56.00 x 5.30	118.00 x 3.55	243.00 x 7.00	650.00 x 7.00
23.60 x 3.55	58.00 x 3.55	118.00 x 5.30	250.00 x 7.00	670.00 x 7.00

## COMPOSITE SEAL

### 7.18 Composite Seal: -

An O-ring can be used as seal for dynamic sealing. O-rings are generally made from elastomeric, such as neoprene, nitrile etc. Such elastomeric material has two main drawbacks. First is that they have higher coefficient of friction, and second is they have poor wear resistance as compared to many plastomer.

To overcome these two drawbacks scientist developed an arrangement in which two rings are used. First ring is made from elastomeric material, which gets pressure energised to produce sealing action, and second ring made from elastomeric material which actually rub against the mating part. As plastomeric material has low coefficient of friction and high wear resistance, hence these types of seal gives much better results.

Plastomeric material is made from combination of PTFE, bronze powder and molybdenum sulphid ( $\text{MOS}_2$ )

PTFE is a wonder material it is chemically almost inert. It has extremely low coefficient of friction. To improve its mechanical properties it is filled with bronze powder. Bronze such as phosphors bronze etc. are best bearing material.

Molybdenum sulphide ( $\text{MOS}_2$ ) best lubricating component and mixed in most of the engine and gear oil. To further reduce coefficient of friction of PTFE and make it self, lubricated ( $\text{MOS}_2$ ) is mixed in PTFE.

A ring made from PTFE, which has filling of bronze and ( $\text{MOS}_2$ ) powder gives best result as seal as guide-ring or as wear ring.

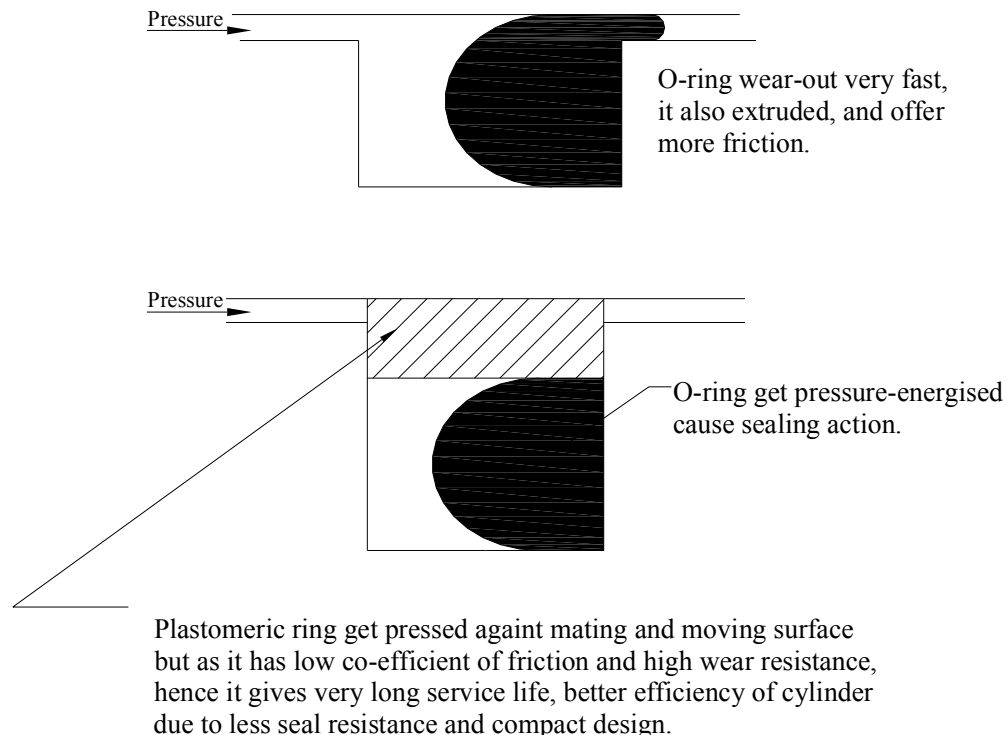

Figure No.7.27

PTFE compound generally have following mixing ratio.

1. 60% Bronze + 40% PTFE
2. 40% Bronze + 60% PTFE
3. 55% Bronze + 5% ( $\text{MOS}_2$ ) + 40% PTFE

Each manufacturer has given above three and many combination their own trade name. And without disclosing the composition, they sale them giving them their own trade name in form of standard strip, ring, o-ring and seal as per international standard.

The two ring type seal, which we described earlier, gives good result, but the flat plastomeric ring may get tilted in reciprocation motion. Hence to improve its performance it is given following shapes.

### 7.18.1 Pyramid type Composite Seal: -

Flat seal get tilted in following way.

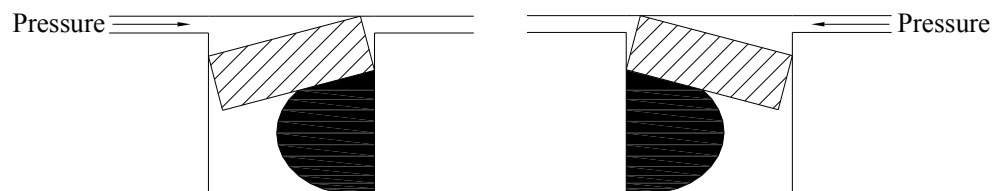

Flate-ring get tilted, resulting in less contact area with mating surface

Figure No. 7.18.1 (a)

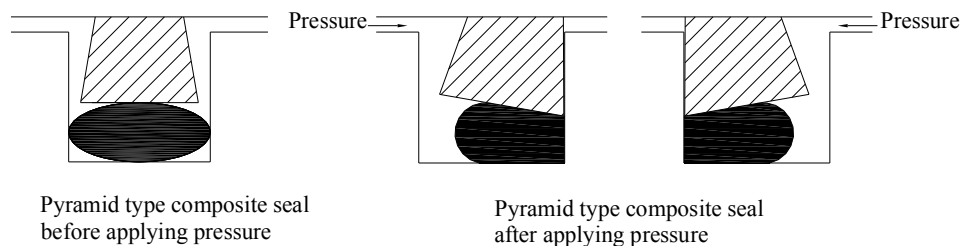

Pyramid type composite seal before applying pressure

Pyramid type composite seal after applying pressure

Figure No. 7.29 (b)

On applying pressure from each side pyramid ring gets tilted due to its peculiar shape, it has full contact area.

### 7.18.2 Contorted Composite Seal: -

In this type the flat plastomeric seal has given concave counter on its inner surface to accommodate the o-ring which remains in its oval shape even after pressuring, hence it does not try to tilt the contorted plastomeric ring and that ring remain in full contact with mating part.

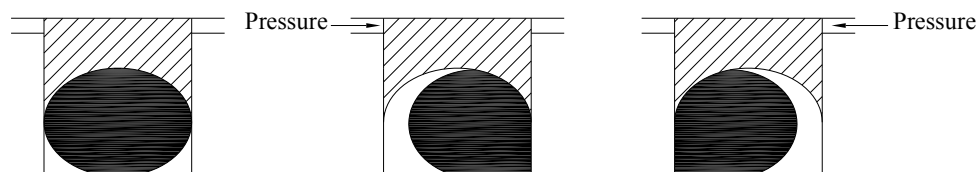

Figure No. 7.18.2

### 7.18.3 Split Ring Composite Seal: -

In this design the plastomeric ring is made in form of two rings. And o-ring is in form of square ring.

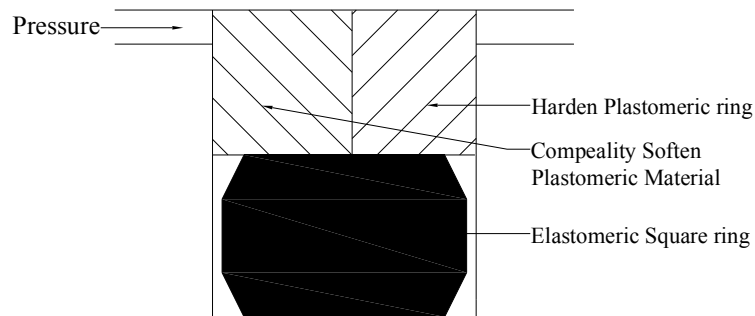

Figure No.7.18.3

These types of seal are generally used as rod seal, for high pressure and which are pressurized in one direction only. Out of two rings one ring is of harder plastomeric material to withstand high pressure and abration, while second offers sealing effect.

### 7.18.4 Wedge type composite seal: -

In this type the flat plastomeric ring is given a special wedge like shape. This type of seal pressurized only in one direction such as rod seal. The wedge type ring tilts after pressurization and get full surface contact with mating surface, and gives good sealing effect. This type of seal can withstand high ressure as compared to other composite type seal. It can be used as high as 700 kg/cm<sup>2</sup>.

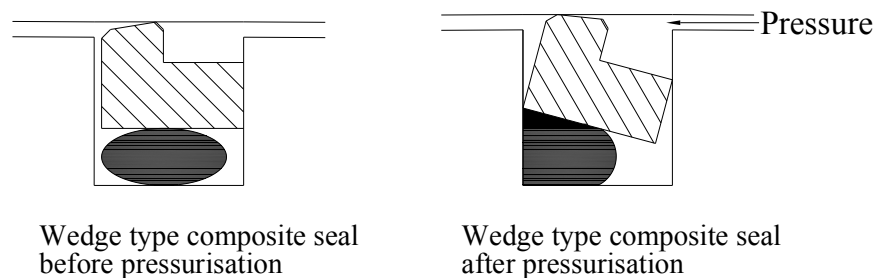
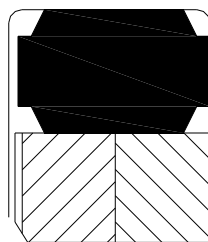

Figure No.7.18.4

Above four types of seal have been further modified and improved by various manufacturers. They have given them their own trade name and patented them. The shape and trade name of Bushak+Shamban and Economos Seals are as follow.

### 7.18.5 Seal Manufactured by Bushak + Shamban: -



Trade name : Glyd Ring<sup>®</sup> HPR

Figure No.7.18.5 (a)

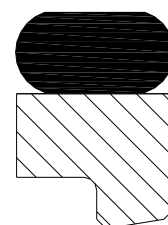

Trade name: Turcon<sup>®</sup> Stepseal K

Figure No.7.18.5 (b)



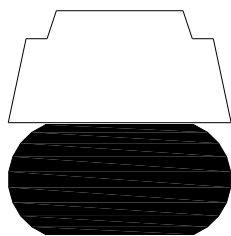

Trade name: Turcon® Glyd Ring® T  
Figure No.7.35 (c)

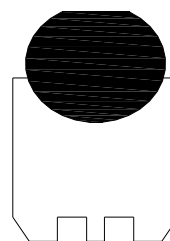

Trade name: Turcon® Roto Glyd Ring®  
Figure No.7.36 (d)

**7.18.6 Seal Manufactured by Economos Seals: -**

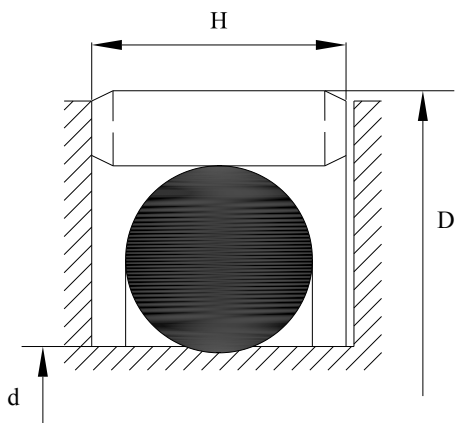

Trade name: K8 Composite piston seal  
Figure No.7.18.6 (a)

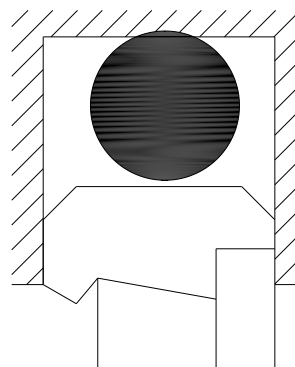

Trade name: S9 Composite rod seal  
Figure No.7.38 (b)

## COMPACT SEAL

**7.18** Piston rubs against Cylinder inner surface, Hence either, it is made from C.I, Aluminum, etc. to avoid scoring or it is provided with guide-rings which are fitted on piston and which avoid direct rubbing of piston with cylinder. As shown in following sketcher.

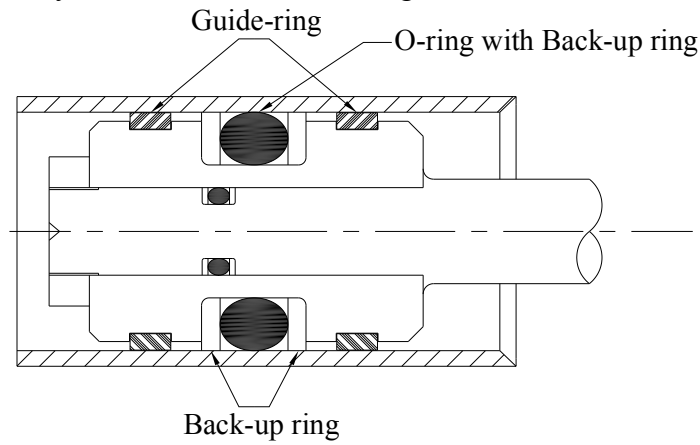

Figure No.7.18

In above design, we have to make three groves to fit O-ring with back up ring and two-guide ring. As some distance is providing between O-ring and guide-ring hence length of piston also increases.

To simplify this sealing arrangement, various combinations have been developed. One arrangement is in which two guide-ring, two back up ring and central O-ring all fitted in one groove. It simplifies the piston machining and also makes piston more compact.

A simple arrangement could be explained as follow.

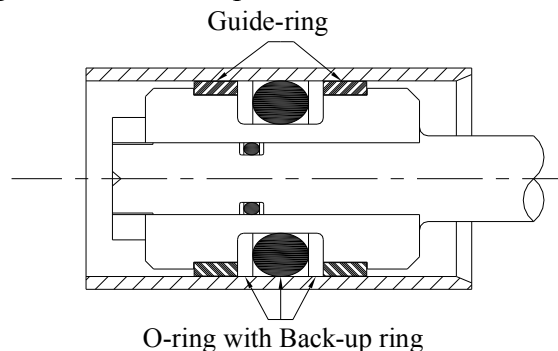

Figure No.7.19

But in above arrangement guide-ring or back up ring can come-out from groove as clearance between them as well as cylinder increases due to wear and tear. Hence again they are further improved to avoid shifting of there ring from there place as well as round O-ring also given various shape to improve inherent draw-back of O-ring such as.

- (1) Back-lash, O-ring has more back-lash than square ring, hence it is replaced with square section ring.
- (2) O-ring easily gets twisted, hence it given locking arrangement with back up ring to avoid twisting.

(3) Flat square-ring have full surface contact with surface of mating surface, when Oil between them squeezes out under pressure, the friction between them increases, resulting in fast wear and tear and heating hence square ring also given groove to retain oil film.

As in this sealing arrangement, guide-ring, back-up ring and basic elastomeric seal ring are combined together to give a compact seal. Which can be used for double action piston, hence it is also named as **compact seal, or double-action-seal (D.A.S.)** for piston.

Various seal manufacturing companies such as Busak-shamban, Economac, James-Walker they have done their own R&D, and developed various shape which according to them gives best result. They have given them their trade name and patented them. Few of such seals are as follow.

### 7.18.1 Seal manufactured by Busak+Shamban: -

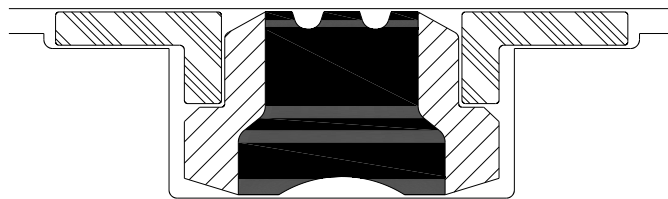

Trade Name - D-A-S Compact Seal

Figure No.7.18.1

### 7.18.2 Seal manufactured by Economic Seals: -

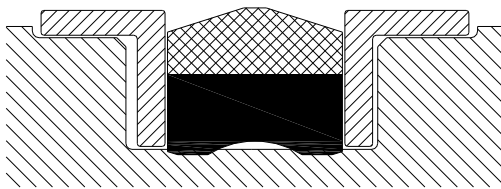

Trade Name - K9 - Double Acting Compact Piston Seal

Figure No.7.18.2 (a)

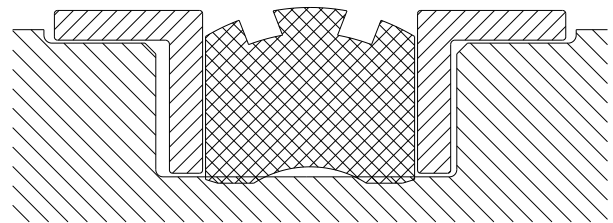

Trade Name - K17 - Double Acting Piston Seal

Figure No.7.18.2 (b)

### 7.18.3 Seal manufactured by James –Walker: -

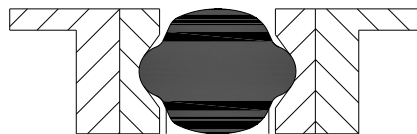

Trade Name - LIONSELE® - SP

Figure No.7.18.3 (a)

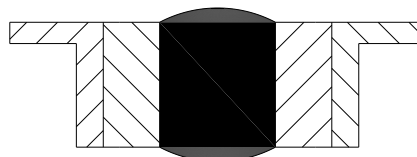

Trade Name - LINOSELE® - SSW

Figure No.7.18.3 (b)

## WIPER SEAL

**7.19** Piston-rod reciprocate in and out from cylinder tube. Surface of piston-rod has thin Oil film, which attracts dust particles. If dust particle enter in the cylinder tube then they will score the piston rod as well as contaminate the oil. Hence to avoid the entry of dust particle and contaminated oil on piston rod to re-enter in cylinder tube, a elastomer seal is used which is called '**Wiper seal**'.

When only oil and dust is to be smoothly and lightly wiped from piston-rod, then seal of rubber like elastomeric material is used and it is known as wiper seal, but when the oil and dust particles from piston-rod is forcefully scraped out from piston-rod then seal ring of hard material is used and it is called '**scraper seal**'. For example cylinders of earth moving machines have scrape as mud also accumulate on cylinder and piston-rod while machine is digging.

Elastomeric retains its elasticity. Hence what ever initial compression is applied on piston-rod, Wiper seal retains that compression, and wipes piston rod for long time.

In case of scraper seal, in which case the deposite on piston rod is to be forcefully scraped, seal made from elastomer will not have strength to do the scraping. Hence seal made from plastomer has to be used. But plastomer do not have elasticity, so what ever initial pre-compression applied, seal will get permanently adjusted to that size, and relief pre-compression and will not scraped the piston-rod, but only touching to it.

Hence to apply some load on this scraper ring made from plastomer (PTFE, or Nylon etc.) a back-up ring of elastomer (High-Nitrile or newprine etc.) is used. Which also get pressure energized if it get any oil leaked from main seal.

Again seal manufacturing companies have made their non shape and size, given them their non trade name, and patented some of which we refer as follow.

### 7.19.1 Seal produced by Busak-Shamban: -

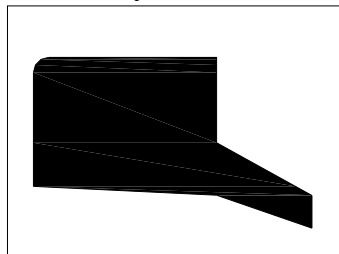

Trade Name - Rod Scraper S.A.

Wiper Seal  
Figure No.7.19.1

### 7.19.2 Seal Produced by Economos Seals: -

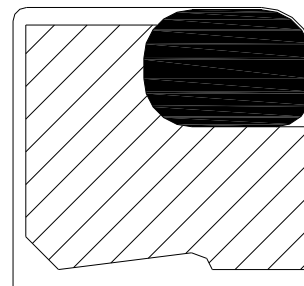

Scraper Seal  
Figure No.7.19.2

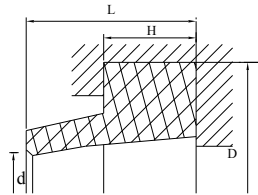

Trade Name - A2 Snap-in wiper hydraulic

**Wiper Seal**

Figure No.7.19.2 (a)

Trade Name - A13 Scraper ring  
(accessory to standard wiper)**Scraper Seal**

Figure No.7.19.2 (b)

Wiper seal or Scraper generally does not perform the function of sealing oil. But nowadays some wiper seal is also designed to seal fluid up to certain extent. They are not main seal to stop-leakage but they are back up or additional support to the principle seal. Sketches of such seal are as follow.

**7.19.3 Seal Produced by Busak+Shamban: -**

Trade Name - Rod Scraper DA22

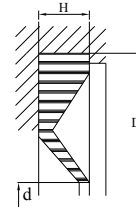
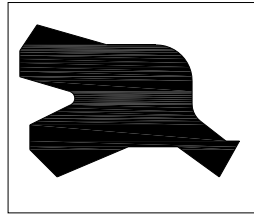
Figure No.7.19.3

**7.19.4 Seal Produced by Economos Seal: -****INSTALLATION OF SEALS****7.20 Installation Of Seals: -**

1. Clean cylinder, piston rod, piston and all component of cylinder thoroughly. Any dust particles will scratch the honed cylinder ID of ground and plated piston rod.
2. Ensure that all edges of cylinder, cylinder piston are chamfered and debarred.

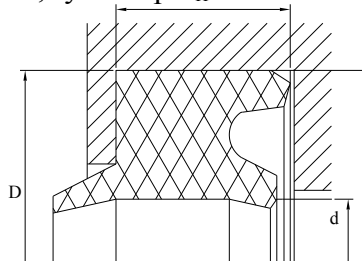

Trade Name - A11 Double lip Snap-in-Wiper

(Hydraulic & Pneumatic)  
Figure No7.20 (a)

3. Oil and grease the component to be assembled.
4. Fiber-impregnated seals absorb moisture hence oil them generously so that dry does not remain in contact with cylinder. Moisture content of fiber will corrode the cylinder ID.
5. U-seal and chevron-packing has longer diameter at lip. For easy assembly of seal in seal pocket, chamfer or entry angle is provided on edge of seal pocket. Seal is placed on seal pocket; lips are pressed inside or in-radial direction and then pressed from top side to push seal in seal pocket. For this screw drivers are brass or aluminum with blunt edges. Sharp edge may damage the seal while screw driver of hard material will scratch the seal pocket and piston rod surface.

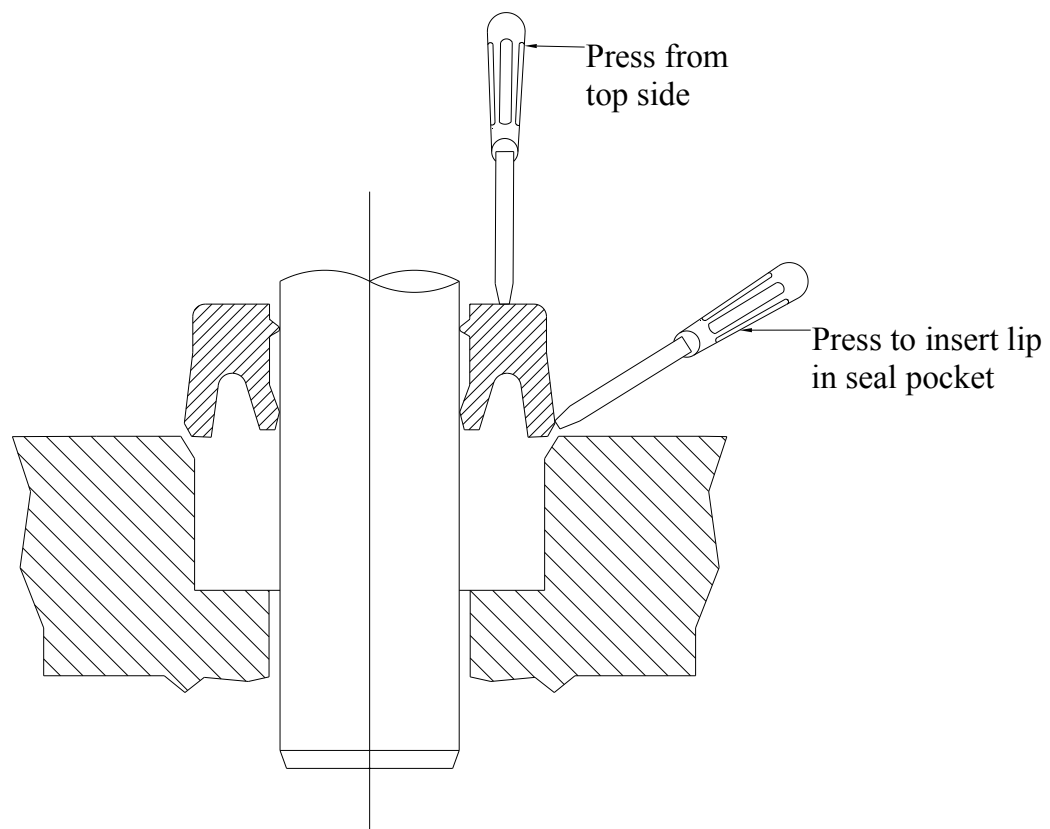

### Installation of Seal

Figure No.7.20 (b)

#### 7.21.1 Installation of Rod-seal: -

These instructions are for installation of composite type of seal.

These types of seals have two seal rings in a seal set. First is made from elastomeric and second is plastomeric material. Elastomer ring could be easily assembled in seal groove. But assembly of plastomeric ring is very difficult and requires special tools. Plastomeric material does not elongate and once they elongate they do not regain their original size. And forcefully they are brought to their original shape, by using “sizing tools”.

1. Debar, clean and inbricate all the seal pocket, sizing tools, and cylinder component to be assembled.
2. Place elastomeric ring into place in seal pocket.
3. Deform the plastomeric seal ring in kidney shape. Push the large area into groove, then push the deformed shape into the groove using by hard pressure. Ensure that seal do not get crease.
4. Push the sizing tool in the bore while twisting and keep their for 2 to 3 minute so that the seal ring regain is original size.

—

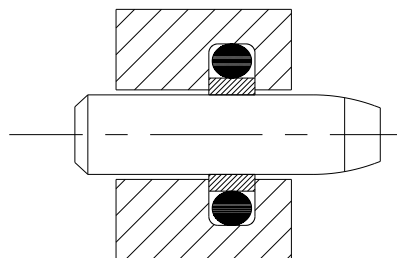
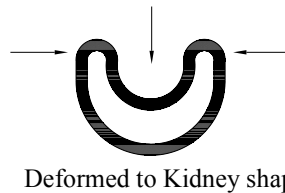
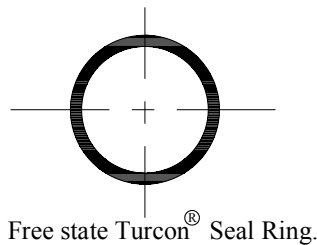
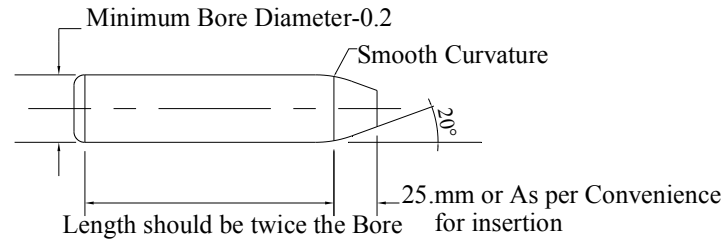

Rod seal installation sequence  
Figure No.7.21.1

4. Place loading mandrel on piston, place seal on loading mandrel, and then in piston groove in its position over elastomeric ring.
5. Push the sizing mandrel over seal while keep on twisting it. So that seal regains its original size. Keep sizing mandrel for 2 to 3 minutes then remove.

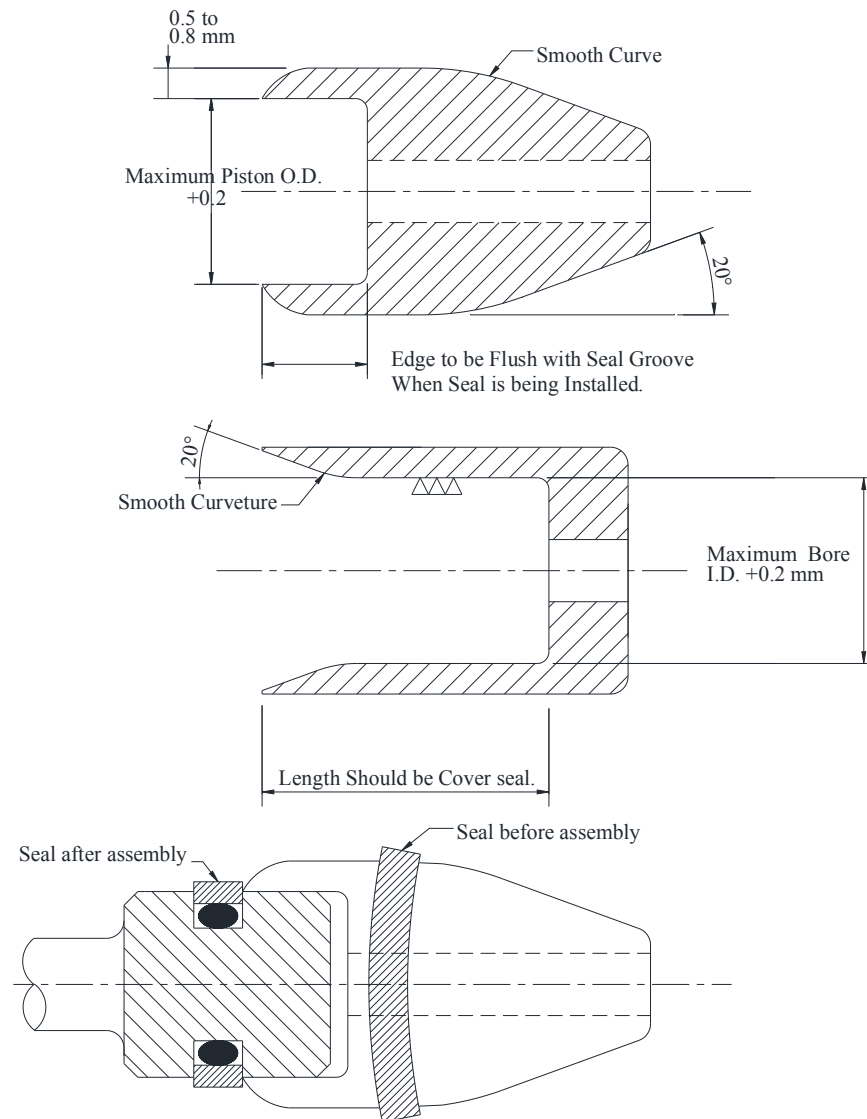

Figure No.7.54  
Piston seal Installation Sequence